

AL-150H

3

Safety Relief Valve

Full bore type	Lift type	Safety valve	Relief valve
Safety relief valve	Lever type	Closed type	Dash-pot structure
Handle type	Stainless	High pressure gas testing products	
Diaphragm	Non-leakage		

■Features

1. Popping structure ensures reliable discharge.
2. Used for the trim parts is SCS14A (equivalent to SUS316) with outstanding corrosion resistance.
3. Simple internal structure facilitates adjustment, maintenance and handling.
4. Closed structure prevents fluid leakage.



■Specifications

Structure	Closed type	
Application	Steam, Air, Cold and hot water, Oil, Other non-dangerous fluids	
Working pressure	1.0-1.6 MPa	
Maximum temperature	220°C *	
Material	Spring case	Cast bronze
	Valve, valve seat	Cast stainless steel (SCS14A)
Connection	JIS Rc screwed	

- * The maximum temperature is 150°C when using for water, oil, or other liquids.
- Please refer to the chart in P.3-76 for set pressure range.

■Dimensions and Weights

Nominal size	Dimension (mm)				Flow area $\pi D \ell$ (mm ²)	Weight (kg)
	di x D x do	L	H ₁	H		
15A	Rc 1/2 x 16 x Rc 3/4	36	42	126	22.9	0.8
20A	Rc 3/4 x 21 x Rc 1	38	47	131	39.5	0.9
25A	Rc 1 x 26 x Rc 1-1/4	46	55.5	147.5	60.6	1.3
32A	Rc 1-1/4 x 33 x Rc 1-1/2	54	61.5	167.5	97.7	1.9
40A	Rc 1-1/2 x 41 x Rc 2	63	67	193.5	150.8	2.9
50A	Rc 2 x 51 x Rc 2-1/2	77	80	241.5	233.4	5.0

- The nominal size and size of screwed end connection are different. The size of screwed end connection have to be one size bigger.

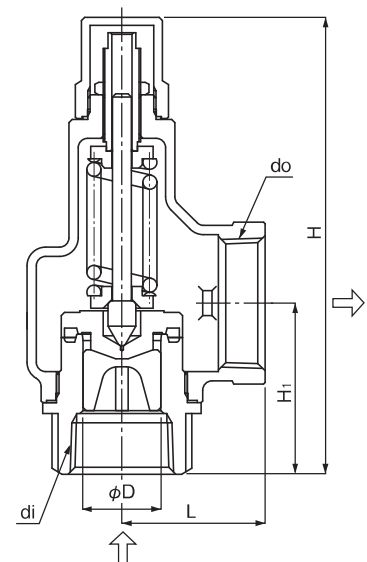

AL-150L

- Full bore type Lift type Safety valve Relief valve
- Safety relief valve Lever type Closed type Dash-pot structure
- Handle type Stainless High pressure gas testing products
- Diaphragm Non-leakage

■Features

1. The trim parts (valve and valve seat) and adjusting spring are made of stainless steel. Used for the trim parts is SCS14A (equivalent to SUS316) with outstanding corrosion resistance.
2. Due to lift lever mechanism a discharge inspection can be manually performed at more than 75% of the opening pressure.

■Specifications

Structure		Open type with a lever
Application		Steam, Air
Working pressure		0.05-1.0 MPa
Maximum temperature		220°C
Material	Spring case	Bronze
	Valve, Valve seat	Stainlesssteel (SCS14A)
Connection		JIS Rc screwed

· Please refer to the chart in P.3-76 for set pressure range.

■Dimensions and Weights

Nominal size	Dimension (mm)					Flow area $\pi D l$ (mm ²)	Weight (kg)
	d	D	L	H ₁	H		
15A	Rc 1/2	16	34	40	148	20.1	0.8
20A	Rc 3/4	21	38	43	148	34.6	0.9
25A	Rc 1	26	43	51.5	165	53.0	1.2
32A	Rc 1-1/4	33	50	61.5	201	93.3	1.9
40A	Rc 1-1/2	41	60	60	226	135.2	2.9
50A	Rc 2	51	75	76	266	208.2	4.8

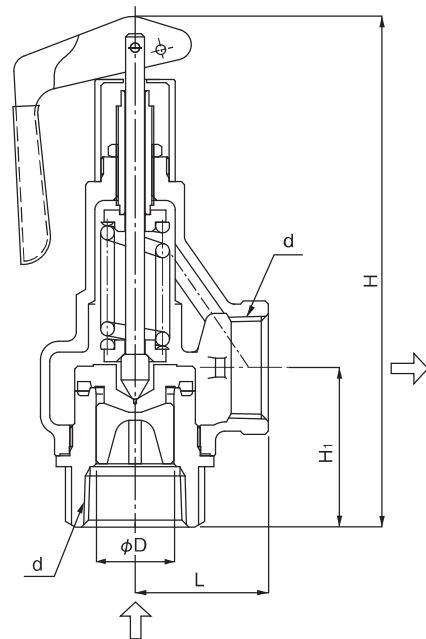

■ Certified Capacity Table

· AL-150L for steam (saturation temperature) <Pressure vessel structure standard> (kg/h)

Pressure MPa Nominal size	0.05	0.1	0.2	0.3	0.4	0.5	0.6	0.7	0.8	0.9	1.0
15A	15	20	29	40	50	60	70	80	90	100	109
20A	27	35	51	69	87	104	121	138	155	172	189
25A	42	54	78	105	133	159	186	212	237	263	289
32A	70	91	132	178	224	268	313	356	400	443	487
40A	105	136	198	266	335	402	468	534	599	664	729
50A	163	211	306	411	518	621	723	824	924	1025	1126

· AL-150H for steam (saturation temperature) (kg/h)

Pressure MPa Nominal size	1.0	1.1	1.2	1.3	1.4	1.5	1.6
15A	115	126	136	146	156	167	177
20A	199	217	235	252	270	288	306
25A	306	333	360	387	415	442	469
32A	493	537	581	625	669	713	757
40A	761	830	897	965	1033	1100	1168
50A	1179	1284	1389	1494	1599	1703	1808

· AL-150L for air (20°C) <Pressure vessel structure standard> (kg/h)

Pressure MPa Nominal size	0.05	0.1	0.2	0.3	0.4	0.5	0.6	0.7	0.8	0.9	1.0
15A	25	33	48	65	81	98	114	131	147	164	181
20A	44	57	83	111	140	169	197	226	254	283	311
25A	67	87	127	171	215	258	302	346	390	433	479
32A	113	147	214	288	362	435	509	582	656	730	803
40A	169	221	321	431	542	652	762	872	982	1093	1203
50A	262	341	496	666	836	1006	1176	1346	1516	1687	1857

· AL-150H for air (20°C) (kg/h)

Pressure MPa Nominal size	1.0	1.1	1.2	1.3	1.4	1.5	1.6
15A	190	208	225	243	260	278	295
20A	328	359	389	419	449	479	509
25A	504	550	597	643	689	735	782
32A	813	888	962	1037	1111	1186	1260
40A	1255	1370	1485	1600	1715	1831	1946
50A	1943	2121	2299	2477	2655	2833	3011

· AL-150H for water (accumulation: 25%) <Yoshitake standard> (m³/h)

Pressure MPa Nominal size	1.0	1.1	1.2	1.3	1.4	1.5	1.6
15A	2.4	2.5	2.7	2.8	2.9	3.0	3.1
20A	4.2	4.4	4.6	4.8	5.0	5.2	5.3
25A	6.5	6.8	7.1	7.4	7.7	8.0	8.2
32A	10.5	11.0	11.5	12.0	12.4	12.9	13.3
40A	16.2	17.0	17.8	18.5	19.2	19.9	20.6
50A	25.2	26.4	27.6	28.7	29.8	30.8	31.8

· Please refer to P.3-11 for the calculation procedure of nominal size selection.