

GP-1000



GP-1000-1002



GP-1200



GP-1010



GP-1001

Features

1. Significantly improved workability and durability compared with conventional pressure reducing valves.
2. Spherical main valve offers great sealability and great reduction of valve seat leakage (compliant with ANSI Class IV).
3. Compliant with SHASE-S106 Pressure Reducing Valves (by the Society of Heating, Air-Conditioning and Sanitary Engineers of Japan).
4. Simple and robust internal structure.

Description of GP-1000 Series model code

GP-1000

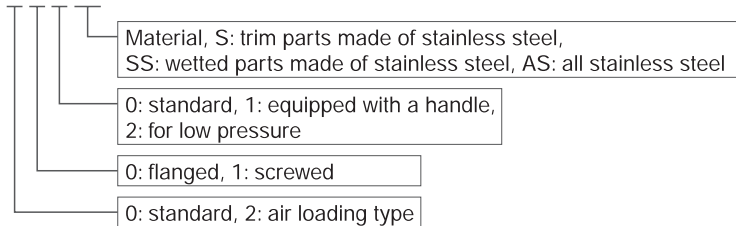

Specifications

Model	GP-1000-1001	GP-1002	GP-1010	GP-1200	GP-1210
Application	Steam				
Inlet pressure	0.1-1.0 MPa	0.1-0.5 MPa	0.1-1.0 MPa		
Reduced pressure	0.05-0.9 MPa	0.03-0.15 MPa	0.05-0.9 MPa		
Minimum differential pressure	90% or less of inlet pressure (gauge pressure)				
Maximum pressure reduction ratio	0.05 MPa				
Maximum temperature	20:1				
Valve seat leakage	220°C				
Material	0.01% or less of rated flow				
Body	Ductile cast iron				
Valve, valve seat	Stainless steel				
Piston, cylinder	Brass or bronze				
Connection	JIS 10K FF flanged		JIS Rc screwed	JIS 10K FF flanged	JIS Rc screwed

• Available with trim parts (piston and cylinder) made of stainless steel (GP-□□□□S).

Dimensions (mm) and Weights (kg)
●GP-1000•1002

Nominal size	L	H1	H	Weight
15A	150	64	285	8.0
20A	155	64	285	8.5
25A	160	67	300	10.0
32A	190	82	323	14.0
40A	190	82	323	14.5
50A	220	93	347	20.0
65A	245	100	357	30.0
80A	290	122	404	35.0
100A	330	144	450	52.5

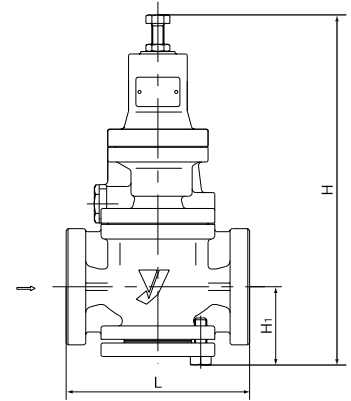
●GP-1010

Nominal size	d	L	H1	H	Weight
15A	Rc 1/2	150	64	285	7.0
20A	Rc 3/4	155	64	285	7.0
25A	Rc 1	160	67	300	8.5
32A	Rc 1-1/4	190	82	323	12.0
40A	Rc 1-1/2	190	82	323	12.5
50A	Rc 2	220	93	347	18.0

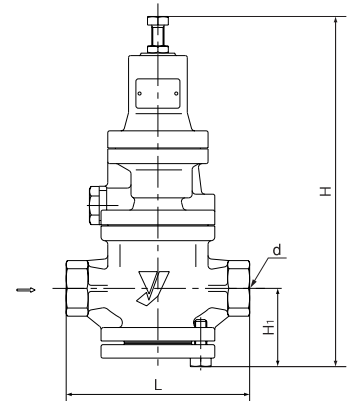
●GP-1200

Nominal size	L	H1	H	Weight
15A	150	64	220	8.0
20A	155	64	220	8.5
25A	160	67	235	10.0
32A	190	82	258	14.0
40A	190	82	258	14.5
50A	220	93	282	20.0
65A	245	100	292	30.0
80A	290	122	339	35.0
100A	330	144	385	52.5

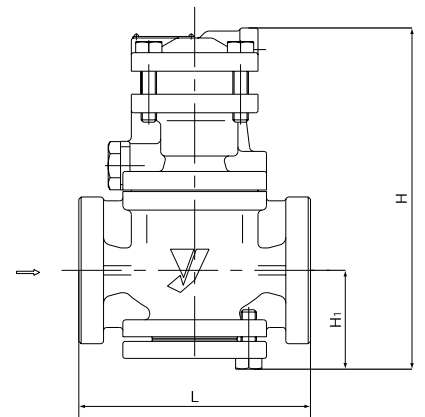
●GP-1210

Nominal size	d	L	H1	H	Weight
15A	Rc 1/2	150	64	220	7.0
20A	Rc 3/4	155	64	220	7.0
25A	Rc 1	160	67	235	8.5
32A	Rc 1-1/4	190	82	258	12.0
40A	Rc 1-1/2	190	82	258	12.5
50A	Rc 2	220	93	282	18.0

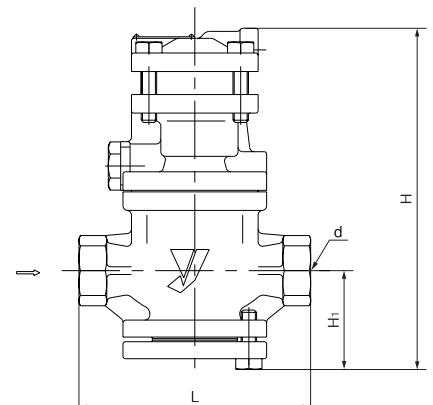

Table of Corrected Cv Values

● Table of rated Cv values (Cv value when the correction factor C = 1)

Nominal size	15A	20A	25A	32A	40A	50A	65A	80A	100A
Cv values	1	2.3	4	6.5	9	16	25	36	64

Note) When the inlet pressure is more than 0.7 MPa and the pressure reduction ratio is more than 10:1, calculate the corrected Cv value by multiplying the rated Cv value by the correction factor C obtained from Fig. 1.

Nominal Sizes Selection Chart (For Steam)

Fig. 1: Corrected Cv value

Specifications Selection Chart

Find the intersection point of the inlet and reduced pressures. If the intersection point is within any of the ranges shown in the chart above, the pressures are controllable.

- Range (A) and (C): GP-1000 Series except GP-1002 and 1012
- Range (B) and (C): GP-1002 and 1012

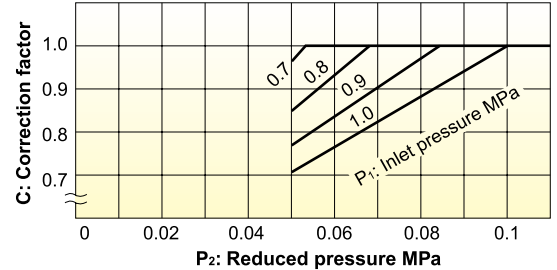
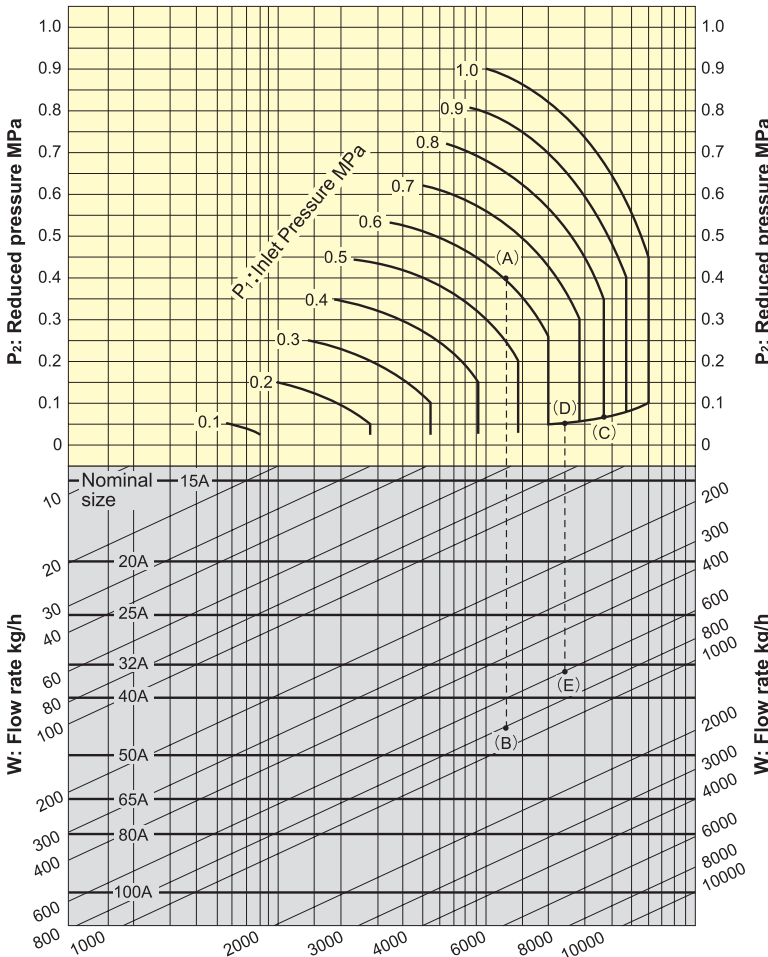
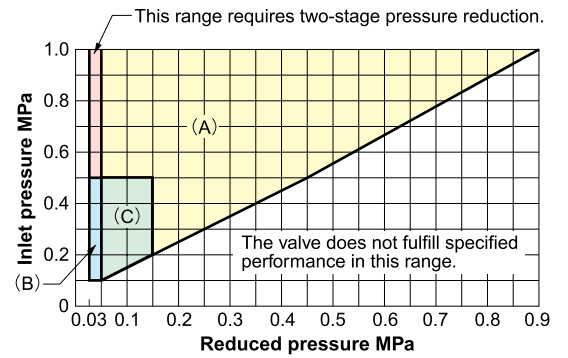
[Example 1]

When selecting the nominal size of a pressure reducing valve whose inlet pressure (P_1), reduced pressure (P_2), and steam flow rate are 0.6 MPa, 0.4 MPa, and 800 kg/h, respectively, first find intersection point (A) of the inlet pressure of 0.6 MPa and the reduced pressure of 0.4 MPa. Trace down vertically from this intersection point to find intersection point (B) with the flow rate of 800 kg/h. Since intersection point (B) lies between nominal sizes 40A and 50A, select the larger one, 50A.

[Example 2]

When selecting the nominal size of a pressure reducing valve whose inlet pressure (P_1), reduced pressure (P_2), and steam flow rate are 0.8 MPa, 0.05 MPa, and 600 kg/h, respectively, first find intersection point (C) of the inlet pressure of 0.8 MPa and the diagonal line. Trace down to the left from this intersection point to find intersection point (D) with the reduced pressure of 0.05 MPa.

Trace down vertically from intersection point (D) to find intersection point (E) with the flow rate of 600 kg/h. Since intersection point (E) lies between nominal sizes 32A and 40A, select the larger one, 40A.

- Set the safety factor at 80 to 90%.

Flow Characteristic Chart

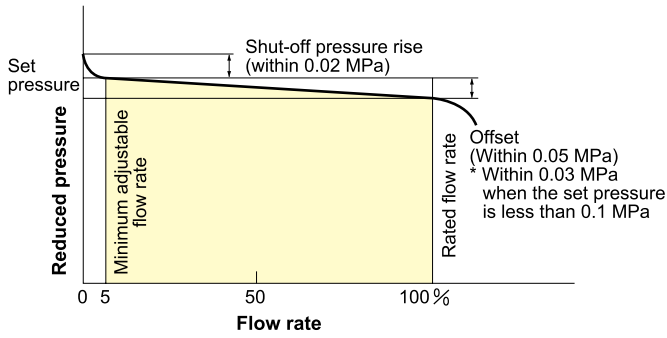

Pressure Characteristic Chart

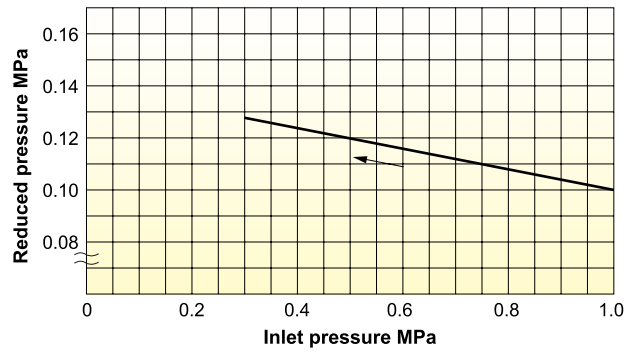

This chart shows variation in reduced pressure when the inlet pressure of 1.0 MPa is changed between 0.3 MPa and 1.0 MPa while the reduced pressure is set at 0.1 MPa.

Loading Air Pressure-set Pressure Chart (GP-1200·1210)

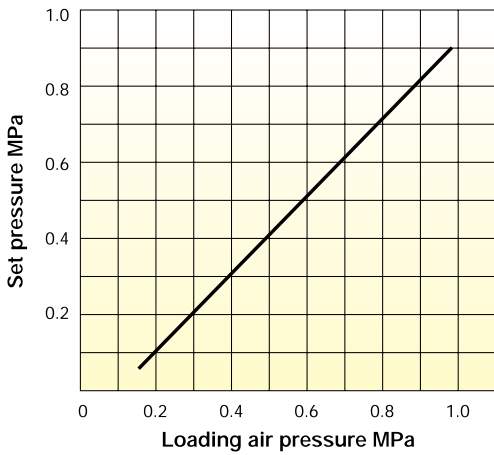

Basically, the set pressure to the loading air pressure is as shown on the left. The set pressure is slightly different depending on the conditions. For the actual use, adjust the loading air pressure suitable for necessary set pressure.

GP-1000 Flow Rate Table

(kg/h)

P ₁ (MPa)	P ₂ (MPa)	15A	20A	25A	32A	40A	50A	65A	80A	100A
1	0.05 *	92	212	369	600	831	1,478	2,310	3,326	5,913
	0.1-0.4	132	303	528	858	1,188	2,112	3,300	4,752	8,448
	0.5	127	292	508	825	1,143	2,033	3,176	4,574	8,132
	0.6	116	268	467	760	1,052	1,871	2,923	4,210	7,484
	0.7	104	239	416	676	936	1,664	2,601	3,745	6,659
	0.8	87	200	348	566	784	1,394	2,179	3,137	5,578
	0.9	63	145	252	410	568	1,010	1,578	2,273	4,042
0.9	0.1-0.4	120	276	480	780	1,080	1,920	3,000	4,320	7,680
	0.5	110	253	441	716	992	1,764	2,756	3,969	7,056
	0.6	98	226	393	639	885	1,574	2,460	3,543	6,299
	0.7	82	190	330	537	744	1,323	2,067	2,976	5,292
	0.8	60	138	240	390	540	961	1,501	2,162	3,844
0.8	0.1-0.3	108	248	432	702	972	1,728	2,700	3,888	6,912
	0.4	103	237	412	670	928	1,650	2,578	3,712	6,600
	0.5	92	212	369	600	832	1,479	2,311	3,328	5,916
	0.6	77	179	311	506	701	1,247	1,949	2,806	4,989
	0.7	56	130	227	369	511	909	1,420	2,045	3,636
0.7	0.1-0.3	96	220	384	624	864	1,536	2,400	3,456	6,144
	0.4	86	197	344	559	774	1,377	2,151	3,098	5,508
	0.5	72	167	291	474	656	1,166	1,823	2,625	4,667
	0.6	53	122	213	346	480	854	1,334	1,921	3,416
0.6	0.1-0.2	84	193	336	546	756	1,344	2,100	3,024	5,376
	0.3	79	182	316	514	712	1,266	1,979	2,850	5,067
	0.4	67	155	270	438	607	1,080	1,687	2,430	4,321
	0.5	49	114	198	322	447	795	1,242	1,788	3,180
0.5	0.1-0.2	72	165	288	468	648	1,152	1,800	2,592	4,608
	0.3	61	141	246	400	554	986	1,540	2,218	3,944
	0.4	45	105	182	297	411	731	1,142	1,645	2,925
0.4	0.1	60	138	240	390	540	960	1,500	2,160	3,840
	0.2	55	126	220	358	496	882	1,378	1,984	3,528
	0.3	41	95	165	268	372	661	1,033	1,488	2,646
0.3	0.1	48	110	192	312	432	768	1,200	1,728	3,072
	0.2	36	83	145	237	328	583	911	1,312	2,333
0.2	0.1	30	70	123	200	277	493	770	1,109	1,972
0.1	0.05	18	41	72	118	164	291	455	656	1,166

* When the inlet pressure is more than 0.7 MPa and the pressure reduction ratio is more than 10:1, calculate the corrected Cv value multiplying the rated Cv value by the correction factor C obtained from Fig.1.