

SLUDGE TREATMENT EQUIPMENT CATALOG



VOLUTE® DEWATERING PRESS AND THICKENER

AMCON INC.

<https://en.amcon.co.jp>

Headquarters	1926, Nippa-cho, Kohoku-ku, Yokohama, Kanagawa 223-0057, Japan	TEL : +81 (0) 45 540 8585 FAX : +81 (0) 45 540 8588
Kyushu Office	2746, Yanaga, Asakura, Fukuoka 838-0031, Japan	TEL : +81 (0) 946 24 0323 FAX : +81 (0) 946 24 0329
Yokohama Assembly plant	2366-1, Nippa-cho, Kohoku-ku, Yokohama, Kanagawa 223-0057, Japan	

Overseas Subsidiaries

China	AMCON(Fujian)Environmental Protection Equipment Co., Ltd. Yuan Hai Three-way, Yuan Hong Investment Zone, Fuqing, Fujian, 350314, China TEL : +86 (0) 591 85267288 http://www.amcon-china.com	Europe	AMCON Europe s.r.o. Za Trati 207, 252 19 Chrastany, Praha-zapad, Czech Republic TEL : +420 211 150120 https://amcon-eu.com/ AMCON Deutschland GmbH Schönbergstrasse 3 34587 Felsberg, Germany TEL : +49 5662 930749 https://amcon-eu.com/de/
-------	---	--------	--



VOLUTE™ Dewatering Press Unlike Any Other

The performance of dewatering equipment is enhanced by removing clogging which could considerably block the discharge of the filtered liquid.

AMCON's dewatering press is equipped with unique VOLUTE™ technology, which allows dewatering sludge while automatically self-cleaning the filter mesh. This enables stable and constant dewatering without depending on flush water for clogging prevention.



**Our job is to
"Provide amenity and convenience which are beyond expectation."**

In 1991, AMCON brought VOLUTE™ into the world where nobody had ever seen such a unique filter element. AMCON's previous experience as an operator of sludge dewatering equipments and wastewater treatment plants urged us to develop a user-friendly machine. After 10 years, we completed the development of VOLUTE™ technology, the filter elements with multiple layered Rings. Continuous efforts for development and improvement of the technology are being made to make the facilities more user-friendly and convenient.

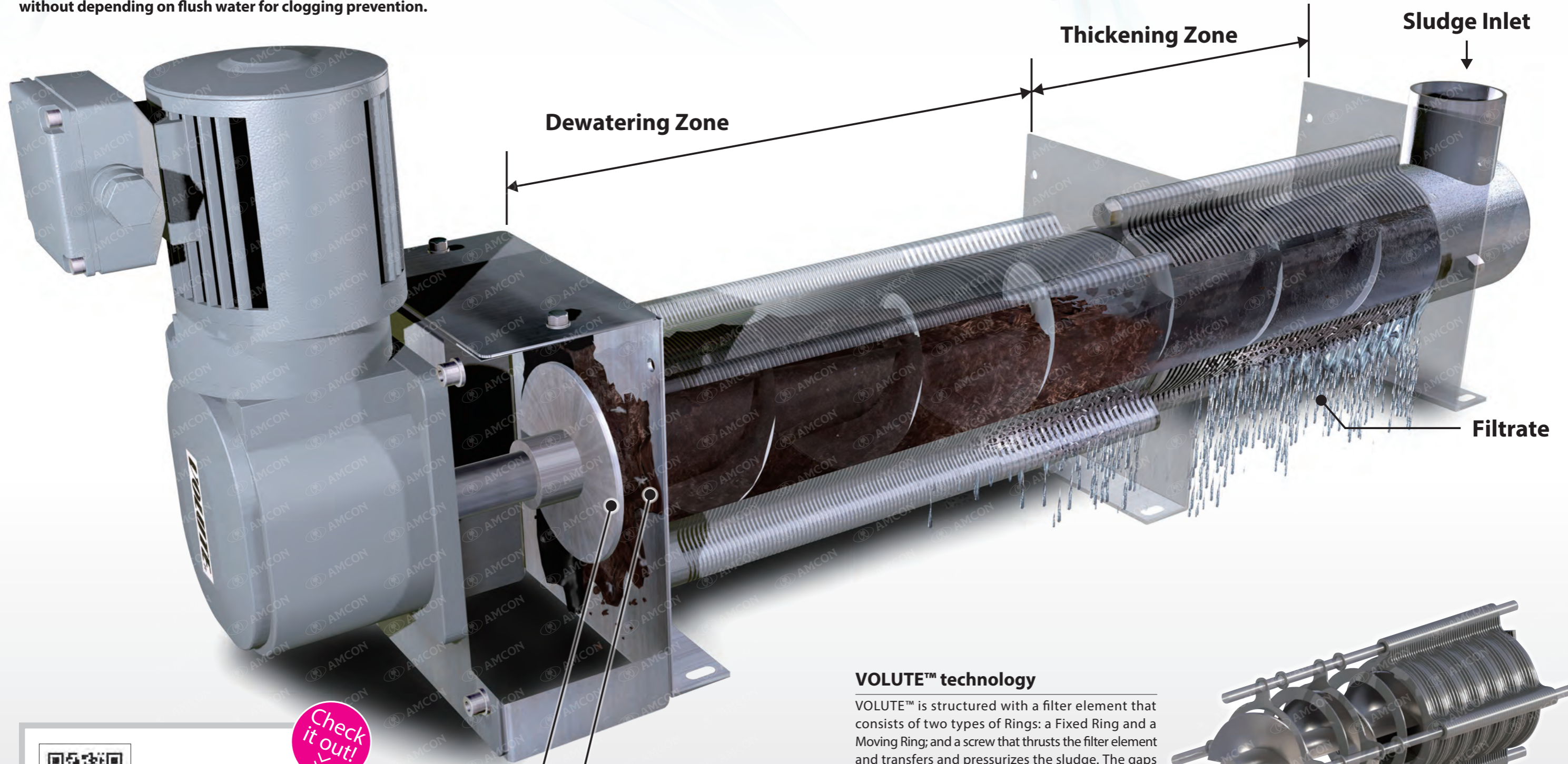

End Plate
Sludge Cake

VOLUTE™ technology

VOLUTE™ is structured with a filter element that consists of two types of Rings: a Fixed Ring and a Moving Ring; and a screw that thrusts the filter element and transfers and pressurizes the sludge. The gaps between the Rings and the screw pitch are designed to gradually get narrower towards the direction of sludge cake outlet and the inner pressure of the filter element increases due to the volume compression effect, which thickens and dewateres the sludge.

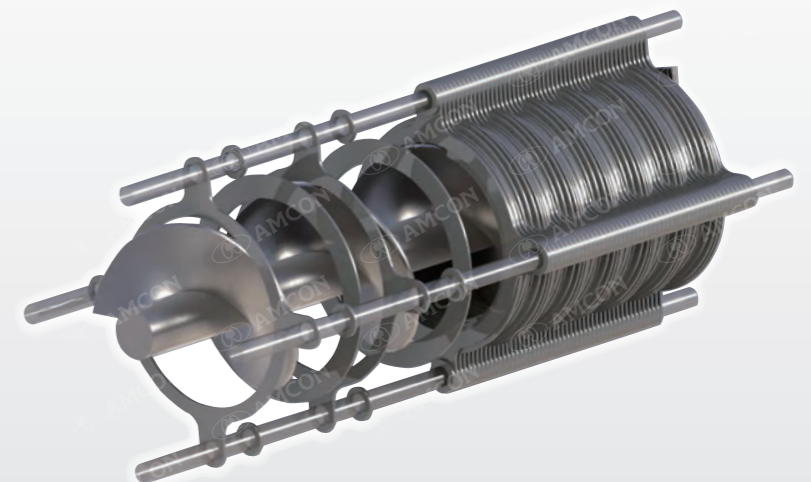

How was VOLUTE™ invented?
For more information, please click the following link.

<http://en-special.amcon.co.jp>



Advantages of VOLUTE™

Easy operation and maintenance

Intuitively understandable operation system adopted. Monitoring of the operation settings is made very easy. 24 hour unattended operation is possible with no daily maintenance.



No pre-thickening required

There is no need to pre-thicken the sludge as it has got 2 built-in thickening functions, first in the Thickening Flocculation Tank and then in the VOLUTE™ cylinder. One compact unit can thicken and dewater the sludge all at once.

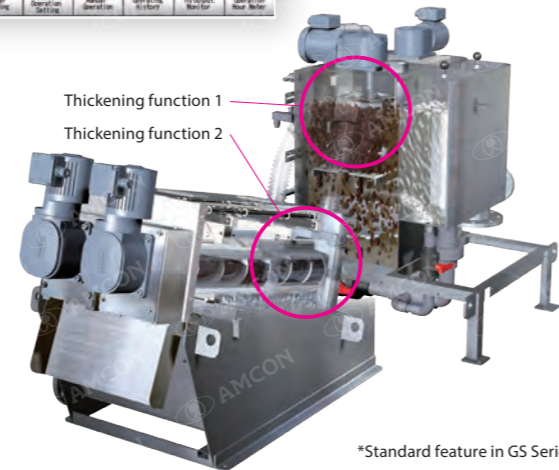

Water-saving

VOLUTE™ prevents filter mesh from clogging with its unique self-cleaning mechanism, removing the need for huge amounts of water for clogging prevention.

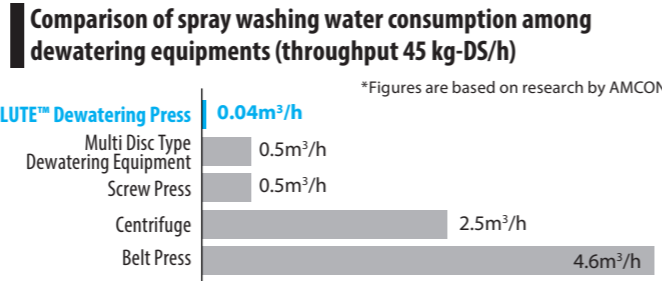

Power saving

The screw which is the main component of VOLUTE™ rotates very slowly at a rate of 2 to 4 rpm, so that it consumes very low power and thus economical.

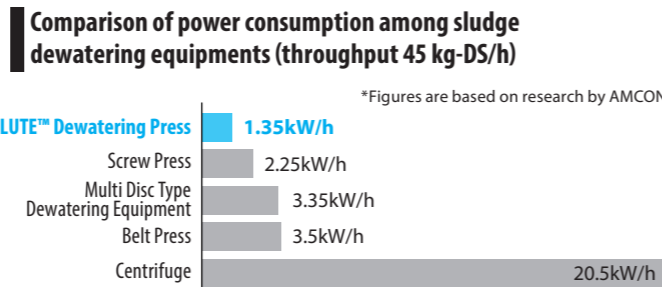

Low noise / Low vibration

Because VOLUTE™ has no rotating body with high speed, there is no concern about noise and vibration. A comfortable work environment can be secured.

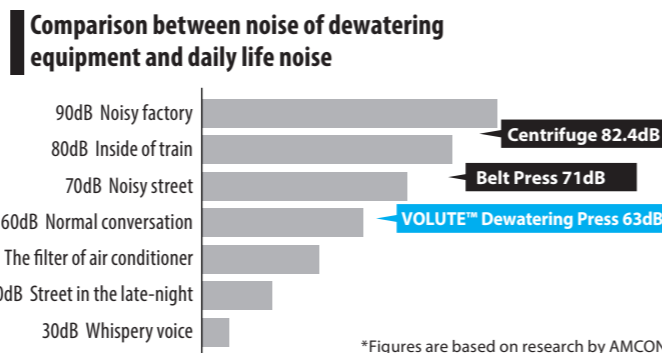

High Resistance to Oily Sludge

The self-cleaning mechanism enables VOLUTE™ to be ideal to dewater oily sludge, which easily causes clogging and is difficult to treat with other types of dewatering equipments.

Small Footprint

VOLUTE™ can be installed in places where placement would not be possible with other technologies. This makes VOLUTE™ suitable to customers who are considering the replacement of existing dewatering equipment.

Two-year Warranty

AMCON products are warrantied for two years as standard. There is also an option to extend it up to 4 years.

* Except for Sludge Dryer K series.

Applicable for Various Applications

Municipal water and wastewater treatment plants, Industrial waste treatment plants, Food/beverage production plants, Dairy farming, Meat processing plants, Chemicals manufacturing plants, Machinery manufacturing plants, Metal processing plants, Laundry wastewater, etc.

Expandable throughput

The throughput of VOLUTE™ can be easily expanded with its Cylinder Unit. We are ready to meet your expectation, "We want to be prepared for the increase of sludge in the future, but without too much increase in the initial cost..."

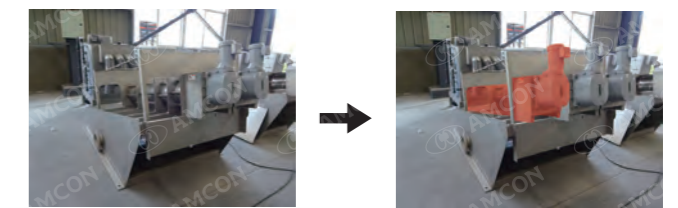

Revolution in sludge treatment VOLUTE™ introduced - Direct dewatering from oxidation ditch* -

In the past times, sludge was commonly thickened before dewatering, but the development of VOLUTE™ Dewatering Press, consisting of a filtering drum with both thickening and dewatering zone, changed this notion. Thanks to the unique structure, VOLUTE™ Dewatering Press can handle low concentrated sludge at 0.2% directly without any pre-thickening stage and is used in a great number of small-scale sewage treatment plants in Japan for dewatering sludge directly from oxidation ditch.

Advantages of direct dewatering from oxidation ditch

- 1, Reduction of investment costs for thickening and storage equipment and operation costs
- 2, Removing odor by dewatering fresh aerobic sludge
- 3, Reduction of the load of phosphorus in the wastewater treatment

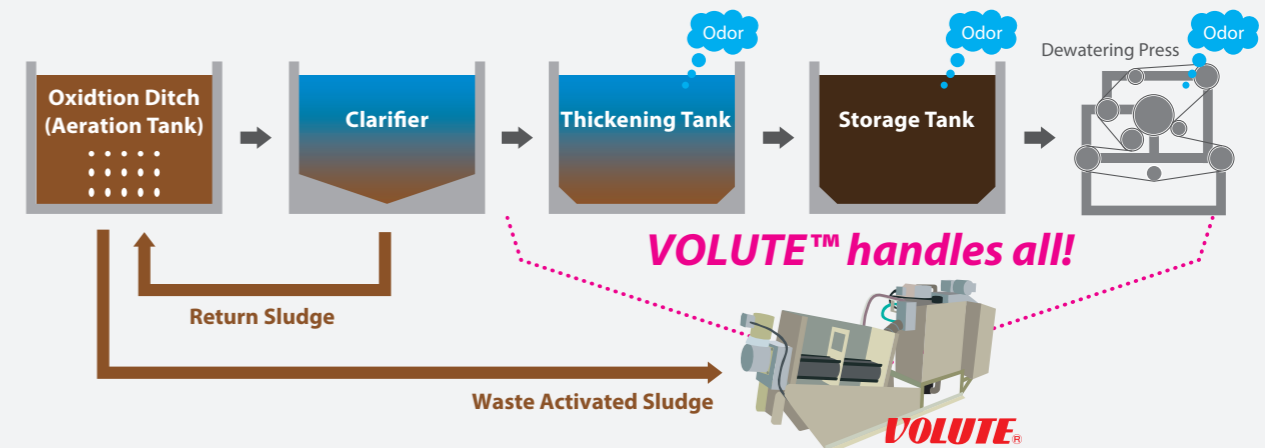

*Demonstrated for the first time ever in the world as a result of the joint research of AMCON and Japan Sewage Works Agency in 1998.

Process Flow

According to customer requirements, two types of main body configurations (with/without sludge conditioning tank) are available.

Model without sludge conditioning tank (GS Series)

3 Cylinder Unit



Sludge is further thickened in the thickening zone of the cylinder, and then the inner pressure increased at the dewatering zone helps sludge being dewatered well.

2 Thickening Flocculation Tank



Polymer flocculant and sludge are stirred and mixed, forming flocs suitable for VOLUTE™. Then, the built-in thickener in the tank instantly thickens the sludge.

1 Flow Control Tank



Sludge feed is regulated with the overflow pipe, returning excess volume to the sludge storage tank.

Polymer Coagulants Inlet

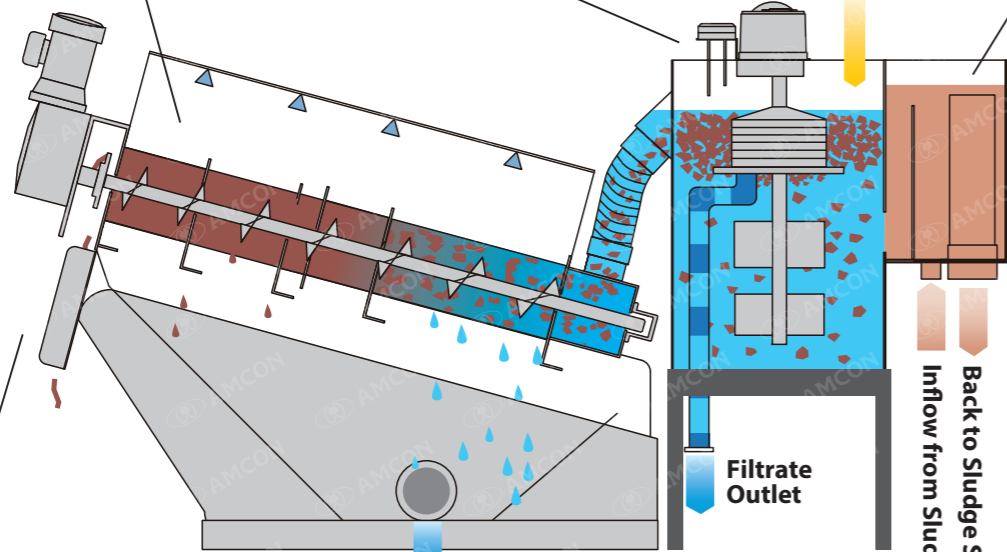

Filtrate Outlet

Filtrate Outlet

Back to Sludge Storage Tank
Inflow from Sludge Storage Tank

4 Discharge Outlet for Dewatered Cake



Further pressure is applied from the outlet side with the End Plate, discharging dewatered cake with 20±5% solids content.



For process flow animation, please click the following link.
<http://goo.gl/zRVK9e>



Model with sludge conditioning tank (EC Series)

4 Cylinder Unit



Sludge is instantly thickened at the thickening zone in the precedent stage, and dewatered at the dewatering zone in the subsequent stage under increasing inner pressure.

3 Flocculation Tank



Polymer and sludge are stirred and mixed, forming flocs suitable for VOLUTE™.

2 Flow Control Tank



Sludge feed is regulated with the overflow pipe, returning excess volume to the sludge conditioning tank.

Polymer Coagulants Inlet

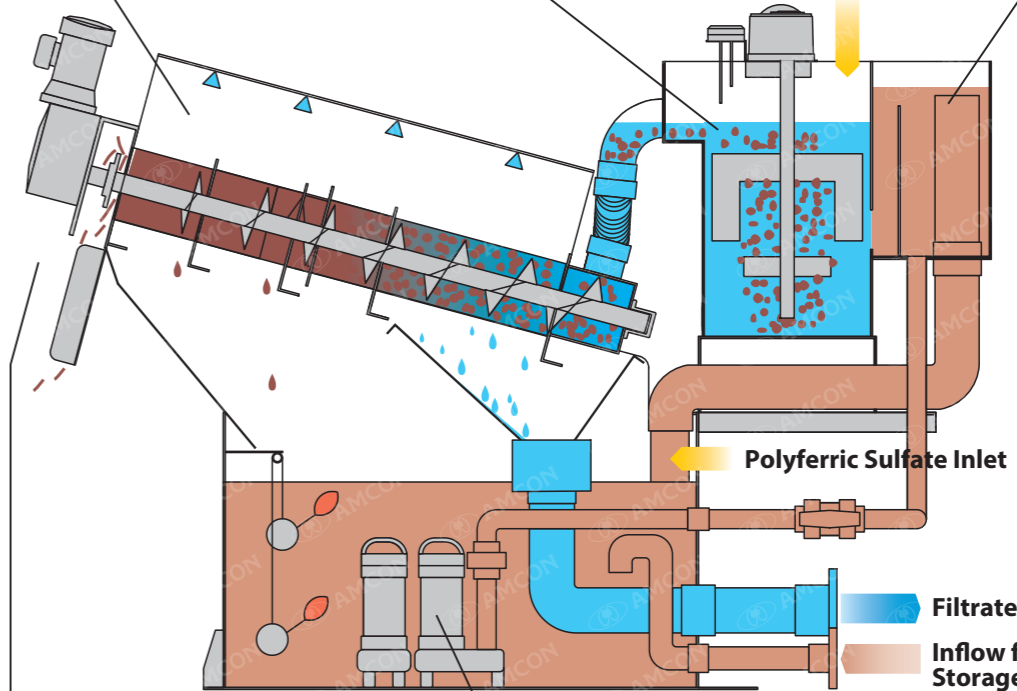

Filtrate Outlet

Inflow from Sludge Storage Tank

5 Discharge Outlet for the Dewatered Cake



Further pressure is applied from the outlet side with the End Plate, discharging dewatered cake with 20±5% solids content.

1 Sludge Conditioning Tank



A sludge conditioning tank temporarily stores sludge before it is dewatered. The model with a sludge conditioning tank realizes a high solid capture rate higher than 95%. When required, the conditioning tank can be used as a reactor tank for inorganic flocculant.

Sludge Dewatering Press VOLUTE™ GS Series

GS series is the high-end dewatering press equipped with various functions. Applying the new pre-thickening mechanism in the flocculation tank, maximum 1.5 times throughput is achieved comparing with FS series.

Also, 'VAS (VOLUTE™ Antilock System)' is normally loaded, which supports the stable operations continuously to achieve a far more User-Friendly model for any operators.

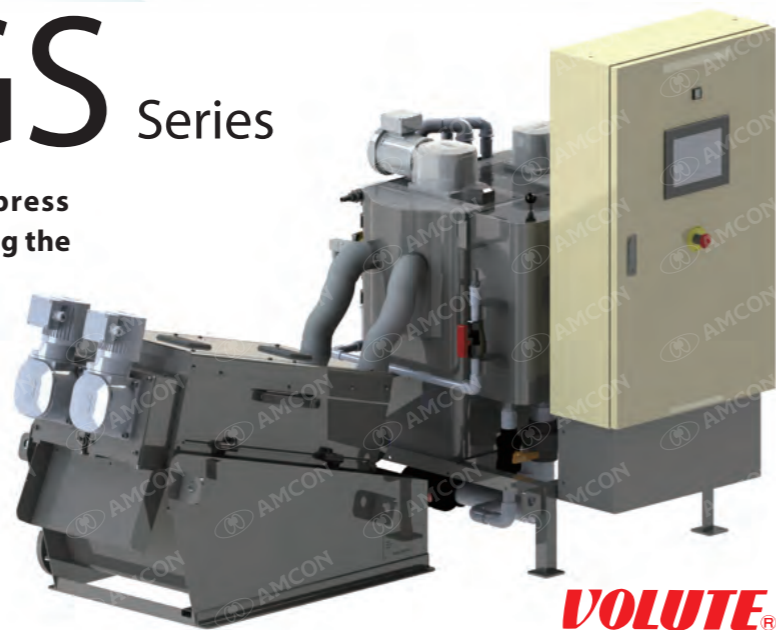

Specifications List

Model	Dimensions(mm)			Total Power Consumption(kW)	Weight(kg)	
	L	W	H		Empty	Operation
GS-101	1900	1105	1440	0.40	330	530
GS-131	2045	1105	1440	0.40	340	540
GS-132	2045	1135	1440	0.50	390	600
GS-201	2485	1105	1440	0.50	500	720
GS-202	3165	1465	1855	1.35	1260	1885
GS-301	3765	1415	1855	1.35	1240	1890
GS-302	3985	1700	1855	1.95	1775	2775
GS-303	4165	2000	1855	2.35	2200	3480
GS-351	4500	1635	2250	2.65	2135	3105
GS-352	5180	1910	2255	5.95	4100	6730
GS-353	5430	2310	2255	7.45	5070	9220
GS-354	5580	2860	2255	8.95	6630	10700
GS-401	5871	1902	2250	4.45	3200	5730
GS-402	6170	2302	2250	5.95	4830	8700
GS-403	5690	3550	2250	10.4	8500	14500
GS-404	5690	3550	2250	11.9	9900	16100

* GS-401 to 404 are scheduled to be released at the end of 2019.

* The specifications of GS-401 to 404 are based on the date derived from their initial stage of development. Thus, they may be subject to change by modification for further improvements.

Layout Drawings

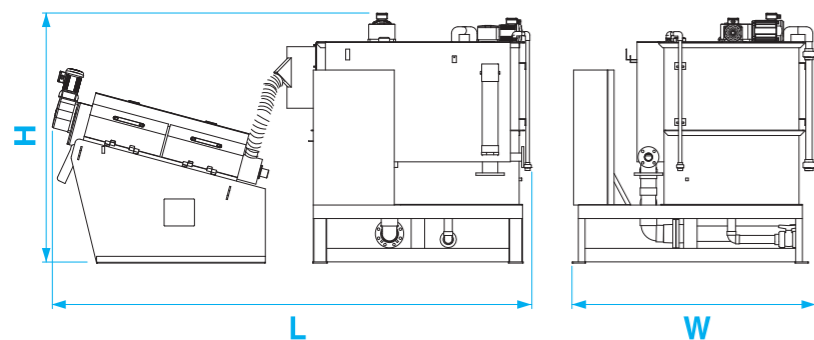

Throughput Range

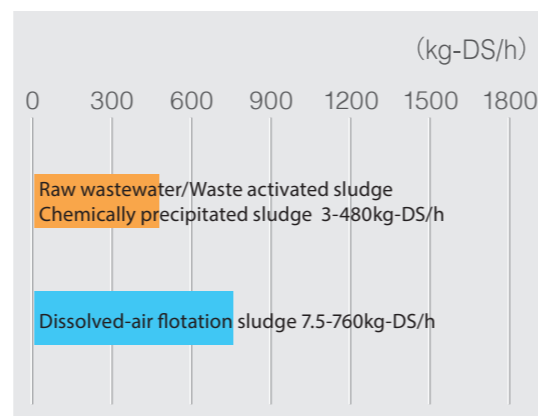

Throughput

Model	Raw Wastewater /Waste Activated Sludge / Chemically Precipitated Sludge		Dissolved-air Flotation Sludge
	0.2%	1.0%	2.0%
GS-101	~ 3kg-DS/h (~ 1.5m³/h)	~ 4.5kg-DS/h (~ 0.45m³/h)	~ 7.5kg-DS/h (~ 0.37m³/h)
GS-131	~ 6kg-DS/h (~ 3.0m³/h)	~ 9kg-DS/h (~ 0.9m³/h)	~ 15kg-DS/h (~ 0.75m³/h)
GS-132	~ 12kg-DS/h (~ 6.0m³/h)	~ 18kg-DS/h (~ 1.8m³/h)	~ 30kg-DS/h (~ 1.5m³/h)
GS-201	~ 13kg-DS/h (~ 6.5m³/h)	~ 20kg-DS/h (~ 2.0m³/h)	~ 33kg-DS/h (~ 1.67m³/h)
GS-202	~ 26kg-DS/h (~ 13.0m³/h)	~ 40kg-DS/h (~ 4.0m³/h)	~ 66kg-DS/h (~ 3.3m³/h)
GS-301	~ 30kg-DS/h (~ 15.0m³/h)	~ 45kg-DS/h (~ 4.5m³/h)	~ 75kg-DS/h (~ 3.75m³/h)
GS-302	~ 60kg-DS/h (~ 30.0m³/h)	~ 90kg-DS/h (~ 9.0m³/h)	~ 150kg-DS/h (~ 7.5m³/h)
GS-303	~ 90kg-DS/h (~ 45.0m³/h)	~ 135kg-DS/h (~ 13.5m³/h)	~ 225kg-DS/h (~ 11.25m³/h)
GS-351	~ 60kg-DS/h (~ 30.0m³/h)	~ 90kg-DS/h (~ 9.0m³/h)	~ 150kg-DS/h (~ 7.5m³/h)
GS-352	~ 120kg-DS/h (~ 60.0m³/h)	~ 180kg-DS/h (~ 18.0m³/h)	~ 300kg-DS/h (~ 15.0m³/h)
GS-353	~ 180kg-DS/h (~ 90.0m³/h)	~ 270kg-DS/h (~ 27.0m³/h)	~ 450kg-DS/h (~ 22.5m³/h)
GS-354	~ 240kg-DS/h (~ 120.0m³/h)	~ 360kg-DS/h (~ 36.0m³/h)	~ 600kg-DS/h (~ 30.0m³/h)
GS-401	~ 80kg-DS/h (~ 40.0m³/h)	~ 120kg-DS/h (~ 12.0m³/h)	~ 190kg-DS/h (~ 9.5m³/h)
GS-402	~ 160kg-DS/h (~ 80.0m³/h)	~ 240kg-DS/h (~ 24.0m³/h)	~ 380kg-DS/h (~ 19.0m³/h)
GS-403	~ 240kg-DS/h (~ 120.0m³/h)	~ 360kg-DS/h (~ 36.0m³/h)	~ 570kg-DS/h (~ 28.5m³/h)
GS-404	~ 320kg-DS/h (~ 160.0m³/h)	~ 480kg-DS/h (~ 48.0m³/h)	~ 760kg-DS/h (~ 38.0m³/h)

* Throughput above is calculated as approximate and may vary depending on sludge condition. For model selection, please contact us.

* Throughput of each model is based on sludge cake with 20±5% solids content.

* There is no certain upper limitation on inlet sludge concentration, however, the target sludge must be flowable.

* Throughput of DAF Sludge is based on sludge containing much fat, oil, and grease such as meat processing applications etc.

Sludge Dewatering Press VOLUTE™ FS Series

FS series is the basic dewatering press equipped with every advantage such as water-saving, power-saving, low noise, and others. In the control panel, PLC touch-screen is applied the same as GS high-end model so that any operators can not only see the current operation of each equipment at a sight but also take easy handling of a machine by finger-touching.



Specifications List

Model	Dimensions(mm)			Total Power Consumption(kW)	Weight(kg)	
	L	W	H		Empty	Operation
FS-101	2131	911	1300	0.3	230	360
FS-131	2276	911	1300	0.3	240	370
FS-132	2361	1027	1300	0.4	320	510
FS-201	2806	1034	1450	0.4	430	620
FS-202	2876	1509	1205	1.0	890	1370
FS-301	3395	1150	1780	1.0	910	1325
FS-302	3890	1470	1844	1.4	1510	2270
FS-351	4114	1325	2250	2.1	1800	2550
FS-352	4775	1645	2250	3.95	2780	3960
FS-401	5700	1650	2250	2.45	2900	4820
FS-402	5900	2000	2250	4.9	5200	7320
FS-403	6500	2700	2250	6.7	7400	11800
FS-404	7000	3200	2250	9.0	8800	14400

* FS-401 to 404 are scheduled to be released at the end of 2019.

* The specifications of FS-401 to 404 are based on the date derived from their initial stage of development. Thus, they may be subject to change by modification for further improvements.

* The above figures are for the models with two chemical inlets. Also, it is possible to provide one chemical inlet models, so please contact us for details.

Layout Drawings

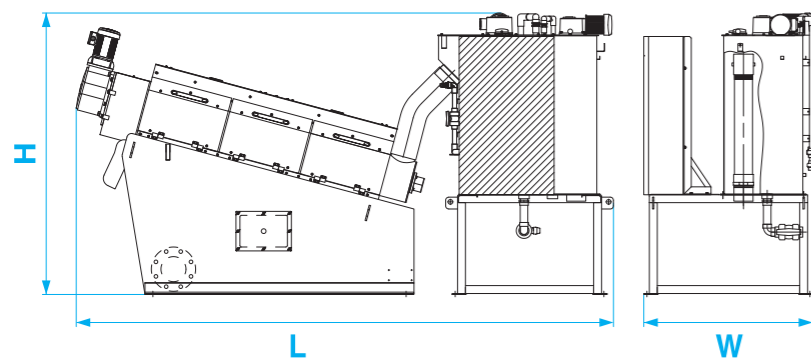

Throughput Range

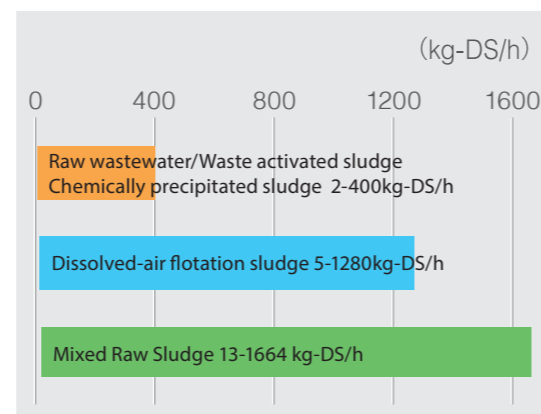

Throughput

Model	Raw Wastewater /Waste Activated Sludge / Chemically Precipitated Sludge		Dissolved-air Flotation Sludge		Mixed Raw Sludge
	0.2%	1.0%	2.0%	5.0%	3.0%
FS-101	~ 2kg-DS/h (~ 1.0m³/h)	~ 3kg-DS/h (~ 0.3m³/h)	~ 5kg-DS/h (~ 0.25m³/h)	~ 10kg-DS/h (~ 0.2m³/h)	~ 13kg-DS/h (~ 0.43m³/h)
FS-131	~ 4kg-DS/h (~ 2.0m³/h)	~ 6kg-DS/h (~ 0.6m³/h)	~ 10kg-DS/h (~ 0.5m³/h)	~ 20kg-DS/h (~ 0.4m³/h)	~ 26kg-DS/h (~ 0.87m³/h)
FS-132	~ 8kg-DS/h (~ 4.0m³/h)	~ 12kg-DS/h (~ 1.2m³/h)	~ 20kg-DS/h (~ 1.0m³/h)	~ 40kg-DS/h (~ 0.88m³/h)	~ 52kg-DS/h (~ 1.74m³/h)
FS-201	~ 8kg-DS/h (~ 4.0m³/h)	~ 12kg-DS/h (~ 1.2m³/h)	~ 20kg-DS/h (~ 1.0m³/h)	~ 44kg-DS/h (~ 0.88m³/h)	~ 57kg-DS/h (~ 1.9m³/h)
FS-202	~ 16kg-DS/h (~ 8.0m³/h)	~ 24kg-DS/h (~ 2.4m³/h)	~ 40kg-DS/h (~ 2.0m³/h)	~ 88kg-DS/h (~ 1.76m³/h)	~ 114kg-DS/h (~ 3.8m³/h)
FS-301	~ 20kg-DS/h (~ 10.0m³/h)	~ 30kg-DS/h (~ 3.0m³/h)	~ 50kg-DS/h (~ 2.5m³/h)	~ 100kg-DS/h (~ 2.0m³/h)	~ 130kg-DS/h (~ 4.33m³/h)
FS-302	~ 40kg-DS/h (~ 20.0m³/h)	~ 60kg-DS/h (~ 6.0m³/h)	~ 100kg-DS/h (~ 5.0m³/h)	~ 200kg-DS/h (~ 4.0m³/h)	~ 260kg-DS/h (~ 8.67m³/h)
FS-351	~ 40kg-DS/h (~ 20.0m³/h)	~ 60kg-DS/h (~ 6.0m³/h)	~ 100kg-DS/h (~ 5.0m³/h)	~ 200kg-DS/h (~ 4.0m³/h)	~ 260kg-DS/h (~ 8.67m³/h)
FS-352	~ 80kg-DS/h (~ 40.0m³/h)	~ 120kg-DS/h (~ 12.0m³/h)	~ 200kg-DS/h (~ 10.0m³/h)	~ 400kg-DS/h (~ 8.0m³/h)	~ 520kg-DS/h (~ 17.3m³/h)
FS-401	~ 65kg-DS/h (~ 32.5m³/h)	~ 100kg-DS/h (~ 10.0m³/h)	~ 160kg-DS/h (~ 8.0m³/h)	~ 320kg-DS/h (~ 6.4m³/h)	~ 416kg-DS/h (~ 13.8m³/h)
FS-402	~ 130kg-DS/h (~ 65.0m³/h)	~ 200kg-DS/h (~ 20.0m³/h)	~ 320kg-DS/h (~ 16.0m³/h)	~ 640kg-DS/h (~ 12.8m³/h)	~ 832kg-DS/h (~ 27.7m³/h)
FS-403	~ 195kg-DS/h (~ 97.5m³/h)	~ 300kg-DS/h (~ 30.0m³/h)	~ 480kg-DS/h (~ 24.0m³/h)	~ 960kg-DS/h (~ 19.2m³/h)	~ 1248kg-DS/h (~ 41.6m³/h)
FS-404	~ 260kg-DS/h (~ 130.0m³/h)	~ 400kg-DS/h (~ 40.0m³/h)	~ 640kg-DS/h (~ 32.0m³/h)	~ 1280kg-DS/h (~ 25.6m³/h)	~ 1664kg-DS/h (~ 55.4m³/h)

* Throughput above is calculated as approximate and may vary depending on sludge condition. For model selection, please contact us.

* Throughput of each model is based on sludge cake with 20±5% solids content.

* There is no certain upper limitation on inlet sludge concentration, however, the target sludge must be flowable.

* Throughput of DAF Sludge is based on sludge containing much fat, oil, and grease such as meat processing applications etc.

* Throughput of Mixed Sludge (Primary Sludge and Waste Activated Sludge) is based on sludge containing 20% fiber (150 micron mesh clearance) against Total Solids. Specifications shall be changed depending on Sludge conditions.

Sludge Dewatering Press VOLUTE™ EC Series

EC series has been evaluated higher in the long-run since it launched in 2001. Having a sludge conditioning tank which enables not only more than 95% solids-capture-rate in filtrate water but also easy installation on site, this model acquires by a lot of customers even now.

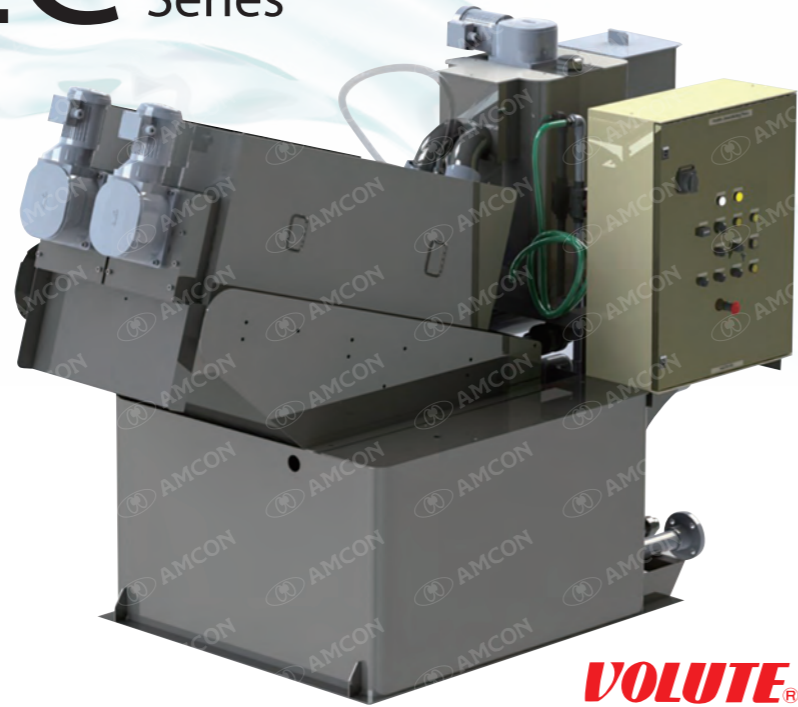

Specifications List

Model	Dimensions(mm)			Total Power Consumption(kW)	Weight(kg)	
	L	W	H		Empty	Operation
EC-101	1757	700	1705	0.7	270	670
EC-102	1757	900	1705	0.8	320	820
EC-131	1757	700	1705	0.7	285	685
EC-132	1757	900	1705	0.8	350	850
EC-133	1847	1100	1705	0.9	420	1070
EC-202	2485	1180	1728	1.45	870	1820
EC-203	2591	1495	1728	1.8	1075	2375
EC-204	2665	1780	1728	2.7	1470	3120
EC-205	2741	2085	1728	2.9	1820	3720

Layout Drawings

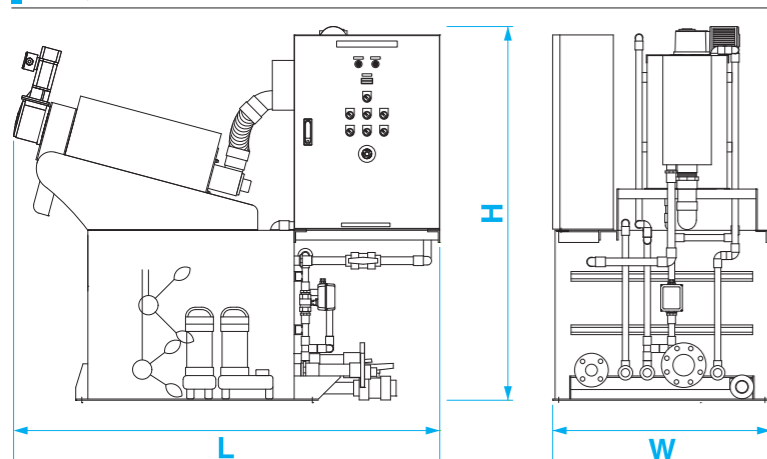

Throughput Range

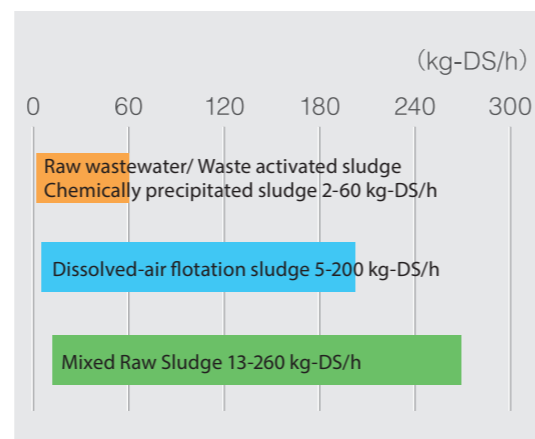

Throughput

Model	Raw Wastewater /Waste Activated Sludge / Chemically Precipitated Sludge		Dissolved-air Flotation Sludge		Mixed Raw Sludge
	Sludge Concentration(TS) 0.2%	1.0%	2.0%	5.0%	3.0%
EC-101	~ 2kg-DS/h (~ 1.0m³/h)	~ 3kg-DS/h (~ 0.3m³/h)	~ 5kg-DS/h (~ 0.25m³/h)	~ 10kg-DS/h (~ 0.2m³/h)	~ 13kg-DS/h (~ 0.43m³/h)
EC-102	~ 4kg-DS/h (~ 2.0m³/h)	~ 6kg-DS/h (~ 0.6m³/h)	~ 10kg-DS/h (~ 0.5m³/h)	~ 20kg-DS/h (~ 0.4m³/h)	~ 26kg-DS/h (~ 0.87m³/h)
EC-131	~ 4kg-DS/h (~ 2.0m³/h)	~ 6kg-DS/h (~ 0.6m³/h)	~ 10kg-DS/h (~ 0.5m³/h)	~ 20kg-DS/h (~ 0.4m³/h)	~ 26kg-DS/h (~ 0.87m³/h)
EC-132	~ 8kg-DS/h (~ 4.0m³/h)	~ 12kg-DS/h (~ 1.2m³/h)	~ 20kg-DS/h (~ 1.0m³/h)	~ 40kg-DS/h (~ 0.8m³/h)	~ 52kg-DS/h (~ 1.73m³/h)
EC-133	~ 12kg-DS/h (~ 6.0m³/h)	~ 18kg-DS/h (~ 1.8m³/h)	~ 30kg-DS/h (~ 1.5m³/h)	~ 60kg-DS/h (~ 1.2m³/h)	~ 78kg-DS/h (~ 2.6m³/h)
EC-202	~ 16kg-DS/h (~ 8.0m³/h)	~ 24kg-DS/h (~ 2.4m³/h)	~ 40kg-DS/h (~ 2.0m³/h)	~ 80kg-DS/h (~ 1.6m³/h)	~ 104kg-DS/h (~ 3.47m³/h)
EC-203	~ 24kg-DS/h (~ 12m³/h)	~ 36kg-DS/h (~ 3.6m³/h)	~ 60kg-DS/h (~ 3.0m³/h)	~ 120kg-DS/h (~ 2.4m³/h)	~ 156kg-DS/h (~ 5.2m³/h)
EC-204	~ 32kg-DS/h (~ 16m³/h)	~ 48kg-DS/h (~ 4.8m³/h)	~ 80kg-DS/h (~ 4.0m³/h)	~ 160kg-DS/h (~ 3.2m³/h)	~ 208kg-DS/h (~ 6.93m³/h)
EC-205	~ 40kg-DS/h (~ 20m³/h)	~ 60kg-DS/h (~ 6.0m³/h)	~ 100kg-DS/h (~ 5.0m³/h)	~ 200kg-DS/h (~ 4.0m³/h)	~ 260kg-DS/h (~ 8.67m³/h)

*Throughput above is calculated as approximate and may vary depending on sludge condition. For model selection, please contact us. Specifications shall be.
 *Throughput of each model is based on sludge cake with 20±5% solids content. Specifications shall be.
 *There is no certain upper limitation on inlet sludge concentration, however, the target sludge must be flowable. Specifications shall be.
 *Throughput of DAF Sludge is based on sludge containing much fat, oil, and grease such as meat processing applications etc. Specifications shall be.
 *Throughput of Mixed Sludge (Primary Sludge and Waste Activated Sludge) is based on sludge containing 20% fiber (150 micron mesh clearance) against Total Solids. Specifications shall be changed depending on sludge conditions.

Sludge Thickener VOLUME™ VT Series

Thickener VT series thickens sludge with concentration of 1% or less to that with a concentration of 4 to 6%.

This mechanical thickening will constantly produce stable thickened sludge, which is difficult with gravity thickening.

It is possible to install as pre-thickener for your existing belt press or centrifuge to improve their dewatering performance.

Furthermore, even in some facilities where the dewatered cakes are not easily transported, the volume of sludge to be disposed of can be reduced by thickening and yet it is still easily transported (pumped) as it is still in liquid form.

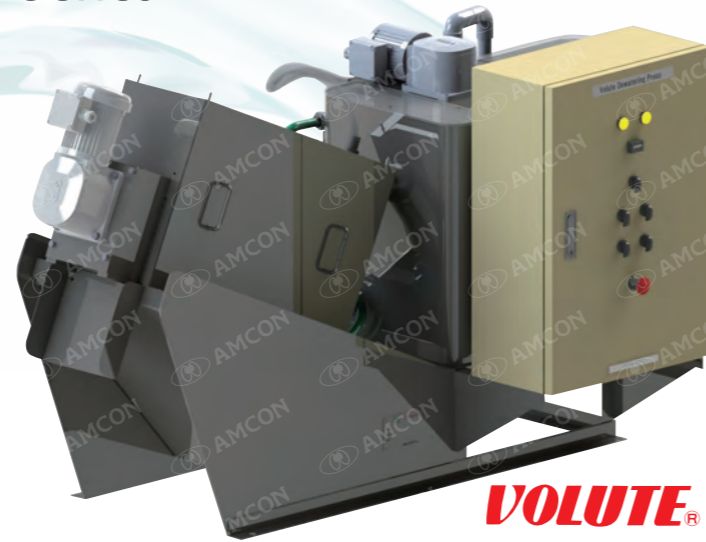

Specifications List

Model	Capacity(Inflow) (m³/h)	Dimensions(mm)			Total Power Consumption(kW)	Weight(kg)	
		L	W	H		Empty	Operation
VT-101	~ 1	1772	901	1250	0.3	160	290
VT-131	~ 3	1772	901	1250	0.3	170	300
VT-201	~ 10	2436	901	1737	1.15	360	680
VT-301	~ 30	3463	1320	2026	1.5	840	1650
VT-302	~ 60	4778	1685	2026	3	1500	4200
VT-303	~ 90	4978	1930	2026	4.45	1950	5550

* Capacity is based on waste activated sludge from biological treatment with TS 0.4% and thickening up to 4% with polymer.
* Figures above is calculated as approximate and may vary depending on sludge condition. For model selection, please contact us.

Layout Drawings

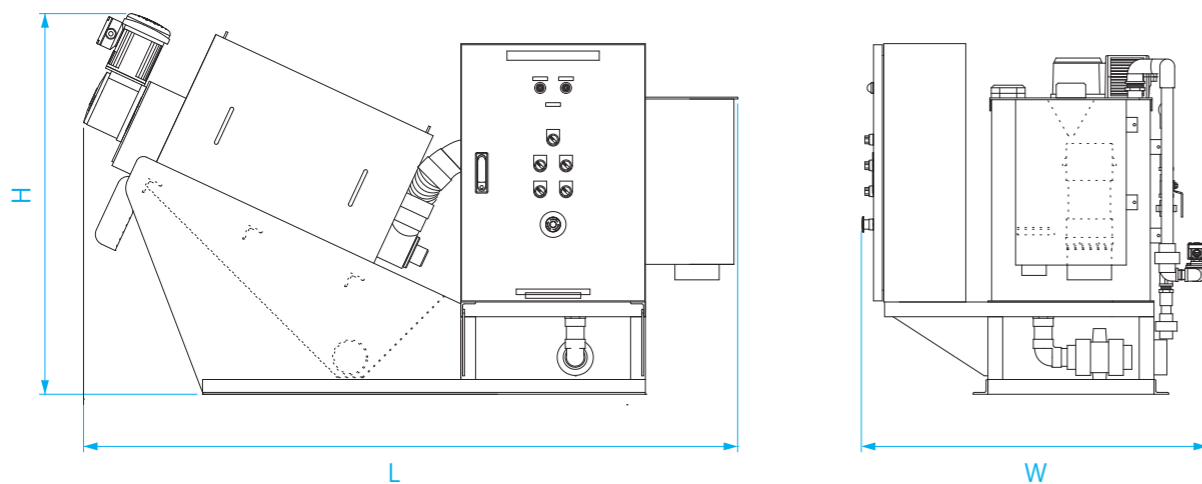

Sludge Dewatering Press VOLUME™

ES-051

ES-051 is the smallest dewatering press in the world which is appropriate for installing in the small scale wastewater treatment plants. This is suitable not only for installing in sewage system, but also for installing in other small facilities such as industrial laundry, vehicle-maintenance factories, and others.



Specifications List

Model	Dimensions(mm)			Total Power Consumption(kW)	Weight(kg)	
	L	W	H		Empty	Operation
ES-051	1095	749	1100	0.2	160	180

Throughput

Model	Raw Wastewater /Waste Activated Sludge / Chemically Precipitated Sludge		Dissolved-air Flotation Sludge
	Sludge Concentration(TS)	0.2%	1.0%
ES-051	~ 0.5kg-DS/h (~ 0.25m³/h)	~ 1kg-DS/h (~ 0.1m³/h)	~ 2kg-DS/h (~ 0.1m³/h)

* Throughput above is calculated as approximate and may vary depending on sludge condition. For model selection, please contact us.
* Throughput of each model is based on sludge cake with 20±5% solids content.
* There is no certain upper limitation on inlet sludge concentration, however, the target sludge must be flowable.
* Throughput of DAF Sludge is based on sludge containing much fat, oil, and grease such as meat processing applications etc.

Layout Drawings

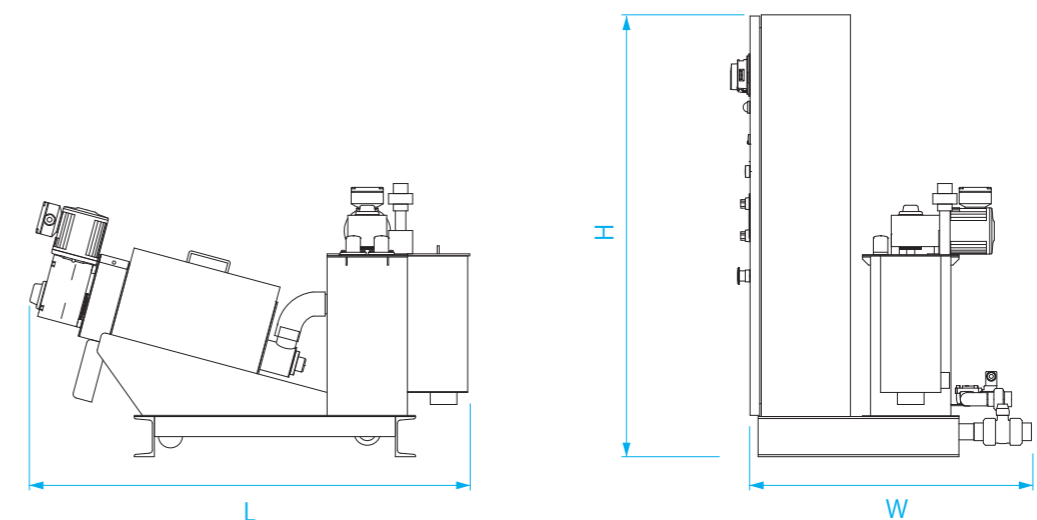

Waste Dry Film Photoresist Dewatering Press

TV-50F

TV-50F is designed to dewater waste photoresist generated from photoresist patterning processes, such as PCB manufacturing. Today, one of the key challenges with business management is reduction of waste generated from production process. TV-50F reduces waste photoresist with high dewatering capacity and helps reduce disposal cost. TV-50F is compact: 844 mm long, 363 mm wide and 555 mm high. It does not require large space.

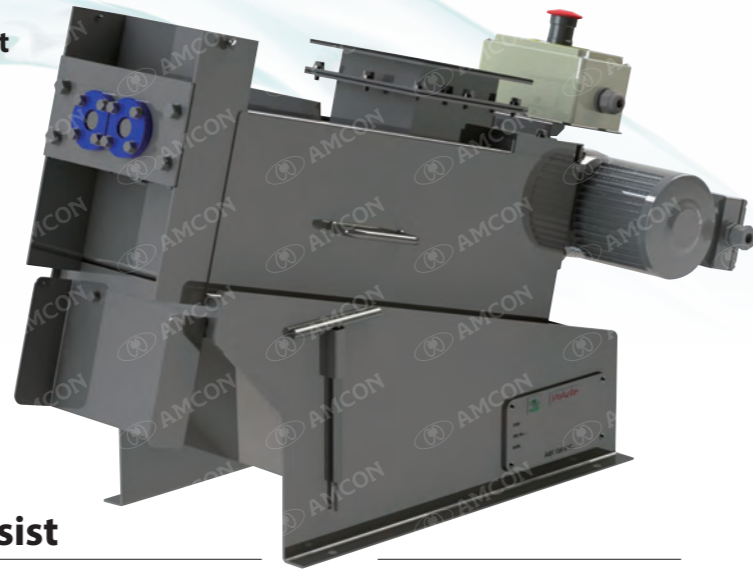

Easier handling of waste photoresist

Before dewatered, waste dry film photoresist is mixed with photoresist remover and the water content is very high. The waste is a strong alkali. It is hazardous and it must be handled carefully in transport and disposal not to spill it. The waste, after dewatered by TV-50F, is like grated cheese and it won't drip the remover solution. That will improve the working environment for transport and disposal.

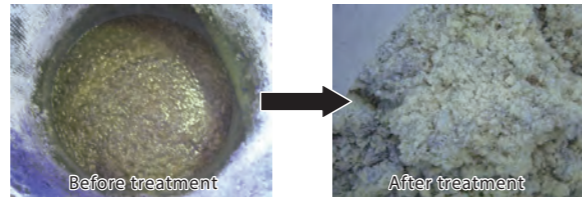

Case Study

Production capacity	360,000 m ² /year (30,000 m ² /month)	Waste reduction by dewatering	50%
Waste generation	60 t/year	Dewatering capacity	30 kg-WET/h max.
Waste disposal cost	100 yen/kg or 20,000 yen/drum	*This cost does not include transport, equipment maintenance, operation and running costs.	

Specifications List

Model	Input (kg-WET/h)	Dimensions(mm)			Total Power Consumption(kW)	Weight(kg)
		L	W	H		
TV-50F	~30	844	363	555	0.1	60

* The hopper for feeding material is optional.

Example of use of TV-50F

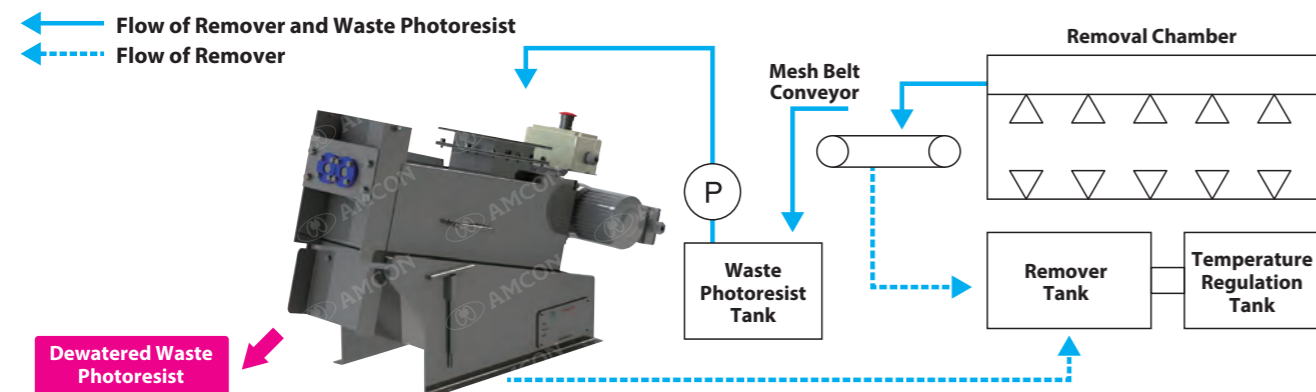

Steam heat source

Sludge Dryer K Series

Sludge dryer, K series is capable of decreasing a great amount of sludge-discharging with Steam-Heating Drum. Using after the sludge process of VOLUTE™ dewatering press, it can make sludge cake (Assuming activated-sludge or chemically precipitated sludge) further drier one which has 10% ~ 40% moisture content.



Sludge Dewatering and Drying System

1 Discharge of dewaterd cake

The dewaterd cake with solid content of about 17%, discharged from the sludge dewatering press, is in turn fed into the dryer.

2 Drying Drum

Sludge is dropped onto the drum surface, and it gets dried during one rotation.

3 Dried cake

Dried cake with solid content of 60 to 90% is discharged.

Specifications List

Model	Throughput (kg-WET/h)	Dimensions(mm)			Required Amount Steam (kg/h)	Total Power Consumption (kW)	Weight (kg)
		L	W	H			
K-510C	~ 9kg-DS/h(~ 60kg-WET/h)	1925	1300	1060	58	0.8	1500
K-515C	~ 14kg-DS/h(~ 93kg-WET/h)	2410	1300	1060	90	0.8	1900
K-810C	~ 15kg-DS/h(~ 100kg-WET/h)	2200	1950	1215	97	1.5	3000
K-815C	~ 22kg-DS/h(~ 146kg-WET/h)	2700	1950	1129	141	1.5	3500
K-820A	~ 28kg-DS/h(~ 186kg-WET/h)	3100	1950	1215	179	1.5	4000
K-12520A	~ 44kg-DS/h(~ 293kg-WET/h)	3975	2900	1650	282	3	8500

* Throughput is based on the standard case in which the dewaterd cake with water content of 85% is treated into dried cake with water content of 40%.
 * Throughput above may vary depending on the conditions of treated sludge or The water content of the materials to be fed into the driver. Please inquire with us for further information.
 * Dimension and weight above are for each single drier.
 * K series is a product of kankyo Setsubi Co., Ltd.

Polymer Make-up System

Liquid Type

AF Series



Powder Type

AP Series



AP Series and AF Series are designed to dissolve polymer, which are used for sludge dewatering and various other wastewater treatment systems, automatically to the specified concentrations of polymer. Automation of dissolving work will drastically save labor cost.

- Save labor by fully automatic operation**
Just refill the stock solution tank / the hopper with polymer, and the device will do the rest from measurement to dissolution.
- Constant concentration**
The concentration of the diluted polymer is kept consistent as the device automatically measures the stock solution and dilution water.
- Interlocked operation with sludge dewatering press or another machine**
The device keeps monitoring the dissolving tank and the stock solution tank / the hopper using sensors. When the level of the polymer is low or when supply of dilution water is inadequate, the device automatically stops and sends a warning signal to external equipment.

Specifications List

AF Series

Model	Dissolving Capacity (L/h)	Stock Solution Tank(L)		Dimensions(mm)			Total Power Consumption(kW)	Weight (kg)	
		Effective Capacity	Operating Capacity	L	W	H		Empty	Operation
AF-50SG	600	40	30	808	811	1010	0.22	120	260
AF-70SG	1350	100	80	1331	1087	1230	0.57	210	750

* Polymer dosing pump is not included within the scope of supply of this product. We will select the corresponding pump based on your requirement. Please consult us.

AP Series

Model	Dissolving Capacity (L/h)	Hopper Capacity (L)	Dimensions (mm)			Total Power Consumption (kW)	Weight (kg)	
			L	W	H		Empty	Operation
AP-S01	150	10	785	925	1280	0.30	130	290
AP-S03	150	30	785	985	1440	0.30	135	310
AP-M03	500	30	1150	1260	1645	0.50	250	785
AP-M05	500	50	1150	1260	1755	0.50	255	800

* Polymer dosing pump is not included within the scope of supply of this product. We will select the corresponding pump based on your requirement. Please consult us.

Water Treatment Chemicals



Polymer Hybrid V has great flocculation efficiency. They are suitable for various types of wastewater treatment systems, such as sludge dewatering presses, dissolved-air flotation (DAF) systems, and chemical precipitation systems. Hybrid V has anionic, cationic, non-ionic and zwitterionic coagulants.

The coagulants also come in two different forms: emulsion and Powder.
 ※Various products are available. Please contact us for more detailed information.



Emulsion



Powder

Case Study:

Mobile VOLUTE™ dewatering press installing in a truck

At Metro Manila district in the Philippines, septic tanks had important roles for the process of WWT to collect wastewater from each area due to lack of the vacant sites and the budget for construction of WWTP. However, there was a great concern for the residents there that was about the pollution of groundwater attributed to the penetrating unclean process-water from underground due to lack of the appropriate management such as the sludge drawing and cleaning of the septic tanks, and others. In terms of this, the appropriate process of the sludge coming from the septic tanks was the urgent issue needed to be dealt with.

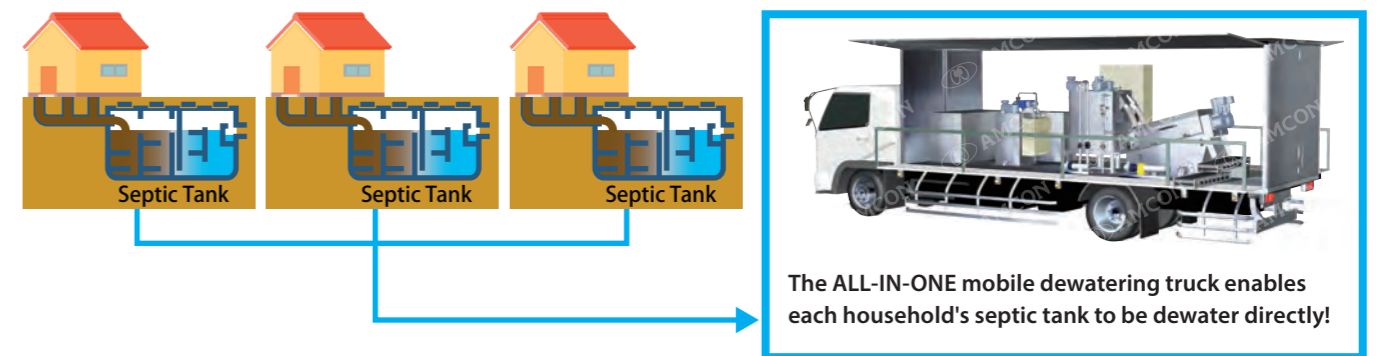

Therefore, we AMCON proposed Mobile VOLUTE™ dewatering press installing in a truck toward government agency (Department of Public works and Highways) which administered the sewage systems and septage-process facilities in the Philippines in order to procure and provide the best solutions by utilizing ODA budget it financed . VOLUTE™ Mobile dewatering press installed in truck visited each house to make the whole process for the sludge evacuated from the septic tanks appropriately. The dewatered sludge became a fertilizer after processing in a composting facility at Metro Manila district. Since then, VOLUTE™ dewatering press has been contributing greatly to not only recycling the sludge but also the living environment there.