

Standardtype

Ventil in Ruhestellung geschlossen - (NC).

Der erregte Magnet öffnet eine Vorsteuerbohrung und hebt direkt oder unterstützt von der Druckdifferenz die Membrane vom Hauptsitz. Das Ventil schließt durch Federkraft.

Standard type

Valve normally closed - NC. When energised, the solenoid will open/free the pilot chamber and the valve will open directly or supported by pressure differential the diaphragm from the valve seat. The valve closes by spring power.



Steuerungsart: Type of control:	zwangsgesteuert force pilot operated	Metall. Innenteile: Metallic internals:	Messing und Edelstahl 1.4104 Brass and stainless steel (AISI 430F)
Konstruktion: Construction:	Sitzventil mit Membrandichtung Diaphragm design	Dichtung: Sealing:	NBR NBR
Anschluss: Connection:	G1/4-G2, DIN ISO 228 G1/4-G2, DIN ISO 228	Einbaulage: Installation:	nur mit stehendem Magneten actuator only in upright position
Druck: Pressure:	0-16 bar (s. Tabelle) 0-16 bar (see table)	Anschlussspannung: Supply voltage:	AC: 24,42,110,230V 50/60Hz DC: 24,110,205V=
Durchflussmedium: Medium:	neutrale, gasförmige u. flüssige Medien neutral, gaseous and liquid medium	Spannungstoleranz: Voltage tolerance:	+10% / -10% +10% / -10%
Viskosität: Viscosity:	22mm ² /s 22mm ² /s	Leistungsaufnahme: Power-consumption:	1012 = 18,5 Watt 0012 = 43/24 VA 1702 / 3702 = 25 Watt 1322 / 3322 = 30 Watt 4242 / 5242 = 46 Watt
Mediumtemperatur: Medium temperature:	-10 bis +80°C (FKM: 0°C-80°C) -10 up to +80°C (FKM: 0°C-80°C)	Schutzart: Protection class:	IP65 nach DIN 40050 IP65 according to DIN 40050
Umgebungstemperatur: Ambient temperature:	+35°C +35°C	Einschaltdauer: Duty factor:	100% ED-VDE 0580 100% ED-VDE 0580
Ventilgehäuse: Body material:	../10../.. = Messing / Brass ../08../.. = Edelstahl 1.4581 Stainless steel (AISI 316Ti)	Kabelanschluss: Cable connection:	Gerätestecker DIN 43650 / Klemmkasten DIN 43650 - Plug / Terminal box

Die Kv-Werte in der Tabelle gelten jeweils für das größte angegebene Magnetsystem!*
In each case, the flow-rate in the table are for the biggest mentioned solenoid system!*

G	Sitz Orifice Ømm	Kv-Wert Flow-rate m ³ /h	Standardtype Standard type	max. Druck bei Magnettype max. pressure regarding solenoid type			
				.012	.702	.322	.242
1/4	13,5	1,8	D4321/..01/....	0-12	0-16*	-	-
3/8	13,5	3,6	D4322/..01/....	0-12	0-16*	-	-
1/2	13,5	3,9	D4323/..01/....	0-12	0-16*	-	-
3/4	27,5	10,8	D4324/..01/....	0-10	0-16*	-	-
1	27,5	13,0	D4325/..01/....	0-10	0-16*	-	-
5/4	40,0	22,0	B4326/..01/....	-	-	0-10	0-16*
6/4	40,0	25,0	B4327/..01/....	-	-	0-10	0-16*
2	50,0	30,0	B4328/..01/....	-	-	0-6	0-16*

Maßzeichnung Standardausführung
Dimensional drawing of standard type

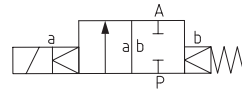
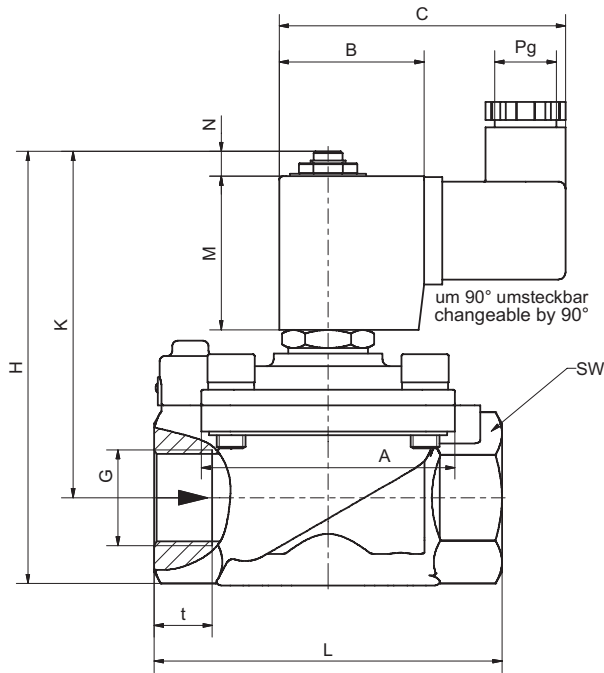

Schaltfunktion/Function:
in Ruhestellung gesperrt - NC.
normally closed - NC.

Anschlussplan / Connection diagram

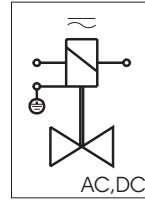

Für Wechsel- und Gleichspannung.
For AC and DC.

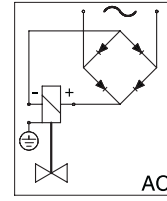

Mit vorgeschaltetem Gleichrichter
für Wechselspannung.
With rectifier for AC connection.

Erdung oder Schutzschaltung nach Vorschrift des zuständigen EVU.
Grounding or earthing of the protective circuit in accordance with regulations of the responsible electric supply company.

Absicherung entsprechend der Stromaufnahme vorsehen.
Appropriate protection according to the power-consumption.

Magnet Solenoid	.012		.702		.322		.242	
Type	4321-4323	4324/25	4321-4323	4324/25	4326/27	4328	4326/27	4328
G	1/4-1/2	3/4-1	1/4-1/2	3/4-1	5/4-6/4	2	5/4-6/4	2
A	44	70	44	70	96	112	96	112
B	35x32	35x32	35x35	35x35	Ø63	Ø63	Ø77	Ø77
C	58	58	66	66	76	82	82	82
H	122	130	132	150	208	242	233	242
K	107	117	119	127	175	207	200	207
L	67	96	67	96	140	168	140	168
M	40	40	50	50	59	59	70	70
N	10	10	10	10	16	19	19	19
SW	27	41	27	41	58	70	58	70
t	12	16	12	16	22	25	22	25
Pg	11	11	11	11	11	13,5	13,5	13,5
kg	1,0	1,6	1,0	1,8	4,5	6,5	5,7	6,5

Ventiloptionen

Stromlos geöffnet = NO
Non energised open = NO

Dichtung = FKM, EPDM
Sealing = FKM, EPDM

Andere Durchflussmedien und Viskositäten
Varying medium and viscosity ranges

Abweichende Temperaturen und Drücke
Varying temperature and pressure ranges

Stellungsanzeiger (Endschalter ab G3/4 mit /.322 Magnet) = EH
Position indicator (Reed contact from G3/4 with /.322 solenoid) = EH

Ex-Schutz = EX II 2G Ex e mb II T4, Ex II 2G EEx md IIC T4 (oder T5)
Explosion proof = EX II 2G Ex e mb II T4, Ex II 2G EEx md IIC T4 (or T5)

Temperaturausführung bis +130°C = TM
Design for high temperature up to +130°C = TM

/

Valve options

Handbetätigung = HA
Manual operation = HA

Regulierbare Schließdämpfung (ab G3/4) = SR
Device for adjustable close damping (from G3/4) = SR

Für Sauerstoffanwendungen = OF
For oxygen applications = OF

Buntmetallfrei = BF
Free of brass and bronze = BF

Abgedichteter Ankerraum = AA
Sealed plunger = AA

Ausführung geeignet zum Einbau mit liegenden Magneten = MF
Mounting of the actuator in hanging position = MF

Andere Exschutzarten auf Anfrage
Further explosion proofs on demand

Stückliste - Parts list

- K1.1 Armatur / Valve body
- K2.1 Deckel / Bonnet
- *K3.1 Vorsteuersitz / Pilot seat
- *K3.2 Membrane / Diaphragm
- *K3.3 Führungstern / Guiding insert
- *K3.4 Vorsteuerspindel / Pilot spindle
- K3.6 Zylinderschraube / Cylinder screw
- *K3.7 Überwurfmutter / Union nut
- *K3.8 O-Ring / O-ring
- K3.10 Verschlussstopfen / Sealing plug
- K3.12 Scheibe / Disk
- K3.13 Dämpfungsschraube / Damping screw
- K3.15 Filteraufnahme / Filter retainer
- *K3.19 O-Ring / O-ring
- *K3.23 O-Ring / O-ring
- *K3.24 O-Ring / O-ring
- K3.25 Filtersieb / Strainer
- *K3.26 O-Ring / O-ring
- *K3.27 6-kt. Mutter / Hexagon nut
- K3.28 6-kt. Mutter / Hexagon nut
- *K3.29 6-kt. Mutter / Hexagon nut
- *K3.30 O-Ring / O-ring
- *K3.31 O-Ring / O-ring
- *K3.33 Feder / Spring
- K5.1 Magnethülse / Solenoid tube
- *K5.2 Magnetanker / Solenoid plunger
- *K5.3 Ankerfeder / Plunger spring
- K5.4 Druckstück / Pressure piece
- K5.5 O-Ring / O-ring
- K5.6 Scheibe / Disk
- K5.7 Zylinderschraube / Cylinder screw
- K5.8 6-kt. Mutter / Hexagon nut
- K5.9 Wellscheibe / Corrugated disk
- K6.1 Magnet / Solenoid
- K7.1 Gerätestecker / Plug

* = Bestandteil des Ersatzteilpäckchens
(je nach Ausführung freibleibend)
* = Part of the service set
(these specifications are without obligation).

Regulierbare Schließdämpfung - SR (von G5/4-G2 serienmäßig)
Device for adjustable close damping - SR
(from G5/4-G2 standard)

Schraube nach rechts drehen : Ventil schließt langsamer
Screw to the right site : Valve closes - slower
Schraube nach links drehen : Ventil schließt schneller
Screw to the left site : Valve closes - faster

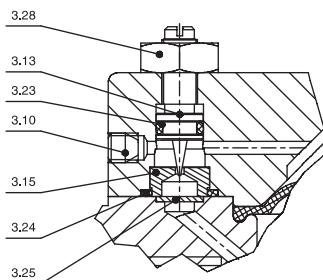

Baureihe / Type D4321-D4323

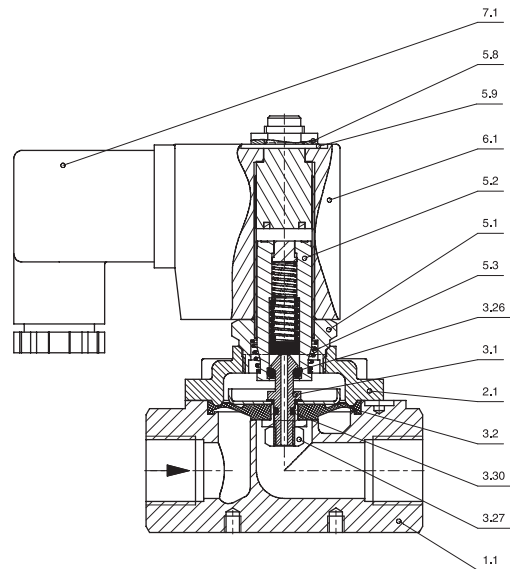

Baureihe / Type D4324 / D4325

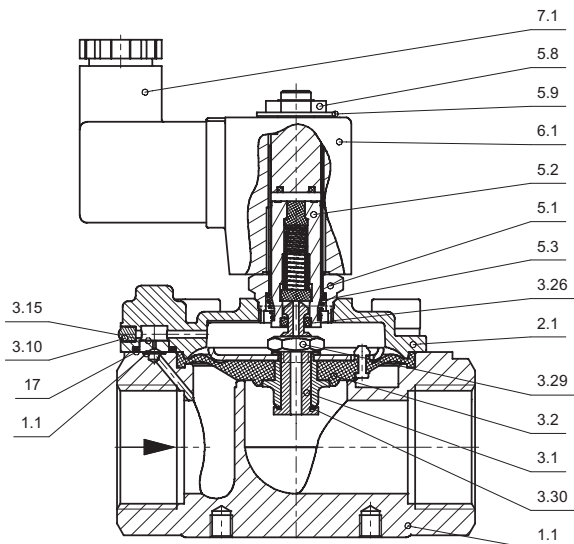

Baureihe / Type B4326 - B4328

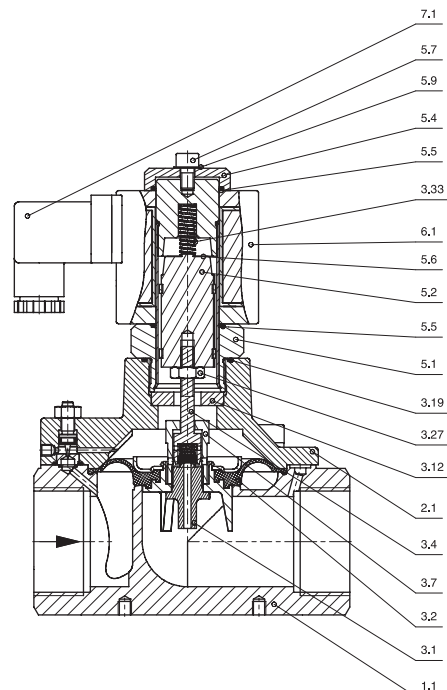

Ventiloptionen / Valve options

Handbetätigung - HA
Manual operation - HA

- K3.61 Zwischenverschraubung / screw joint
- K3.62 Spindel / Spindle
- K3.63 Verschraubung / Screw joint
- K3.64 Scheibe / Disk
- K3.65 Nutring / U-ring
- K3.66 O-Ring / O-ring
- K3.67 Handrad / Handwheel
- K3.68 Zylinderschraube / Cylinder screw

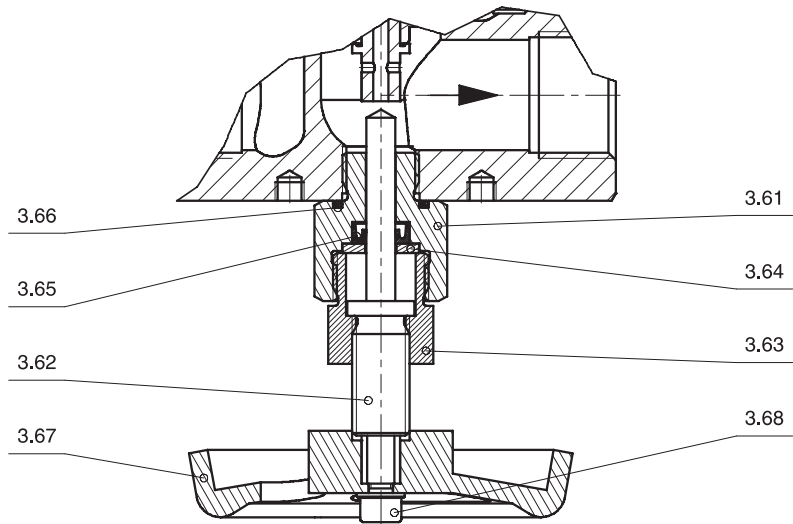

Stellungsanzeiger - EH (ab G3/4 mit Magnet / .322)
Position indicator - EH (from G3/4 with solenoid / .322)

- K3.33 Feder / Spring
- K3.75 Zwischenverschraubung / Screw joint
- K3.76 Spindel / Spindle
- K3.77 Befestigungsmutter / Mounting nut
- K3.79 O-Ring / O-ring
- K3.82 Senkschraube / Countersunk bolt
- K3.83 Permanentmagnet / Permanent magnet
- K3.84 Klemmring / Clamping ring
- K3.85 Verschraubung / Screw joint
- K3.86 Endschalter / Position indicator
- K3.87 Scheibe / Disk
- K5.1 Magnethülse / Solenoid tube
- K5.2 Magnetanker / Solenoid plunger
- K5.5 O-Ring / O-ring
- K5.6 Scheibe / Disk
- K6.1 Magnet / Solenoid

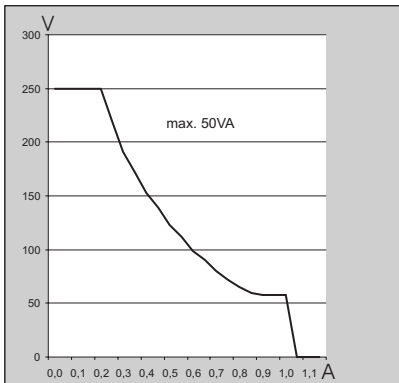
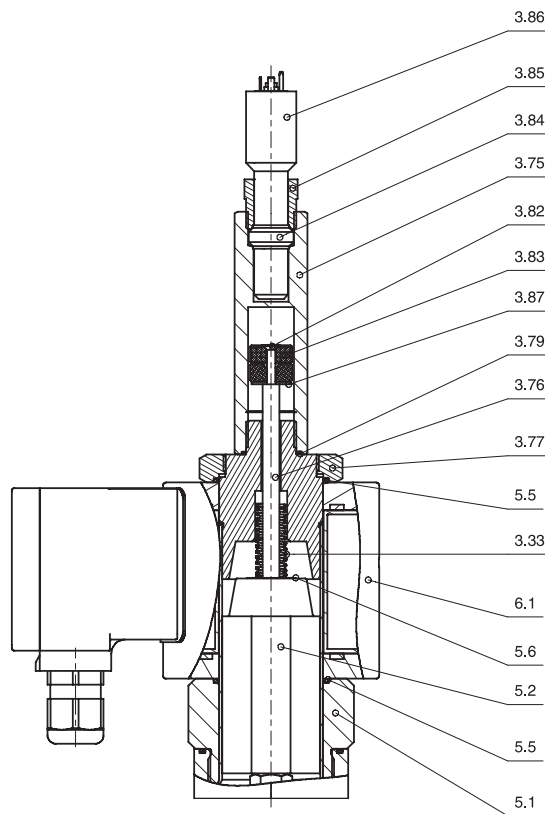

Schaltleistungsdiagramm
Braking capacity diagram

Anschlussplan
Connection diagram

Endschalter / Position indicator

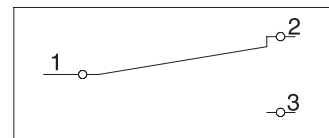

GSR Ventiltechnik GmbH & Co. KG
Postfach 2060 • D-32595 Vlotho • Im Meisenfeld 1 • D-32602 Vlotho
Telefon +49 5228 779-0 • Telefax +49 5228 779-190
E-mail: info@ventiltechnik.de www.ventiltechnik.de