

Long Neck Type *Gear Operated*

G-10XJME
G-10XJMEA
G-PN16XJME

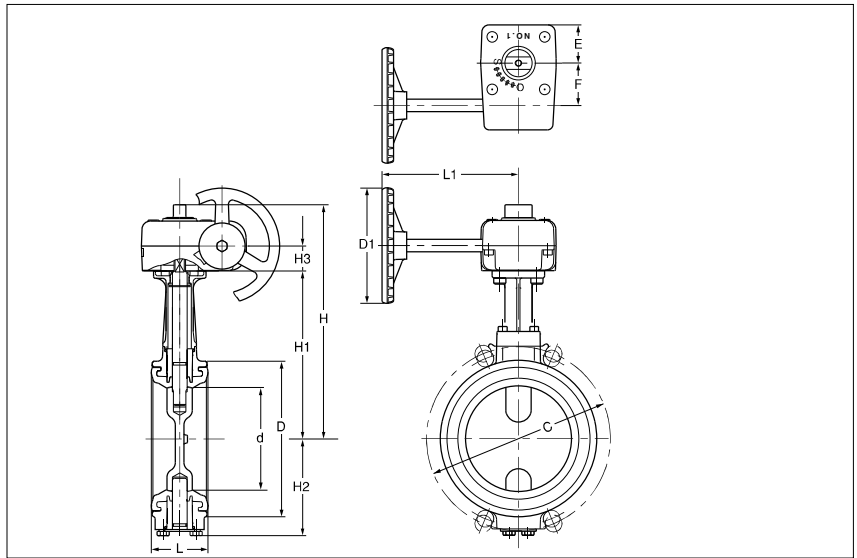

Dimensions

unit : mm

Size		d	H	H1	H2	H3	L	D	C			D1	L1	E	F	Gear type
mm	inch								10K	Class150	PN16					
40	1½	40	177	130	60	19	33	78	105	—	—	80	122	29	28	No.0
50	2	50	179	132	66	19	43	93	120	120.5	125	80	122	29	28	No.0
65	2½	65	188	141	74	19	46	118	140	139.5	145	80	122	29	28	No.0
80	3	80	212	149	83	24	46	129	150	152.5	160	110	135	36	40	No.1
100	4	100	223	160	94	24	52	149	175	190.5	180	110	135	36	40	No.1
125	5	125	257	195	122	24	56	184	210	216	210	110	150	36	40	No.1
150	6	150	270	207	135	24	56	214	240	241.5	240	110	150	36	40	No.1
200	8	196	310	234	161*	32	60	258	290	298.5	295	170	180	51	63	No.2
250	10	245	405	328	238	32	68	316	355	362	—	170	180	51	63	No.2
300	12	295	430	353	263	32	78	367	400	—	—	170	180	51	63	No.2

*PN16XJME H2=183