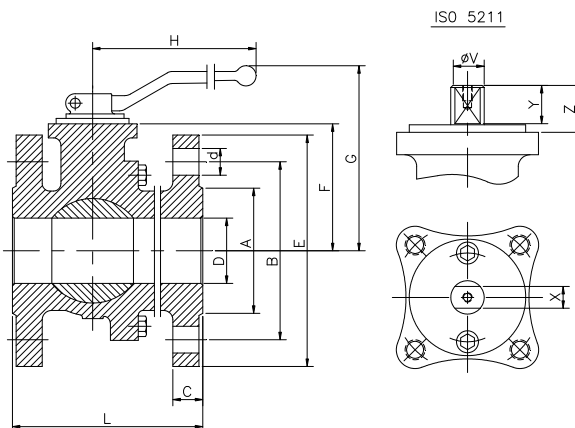
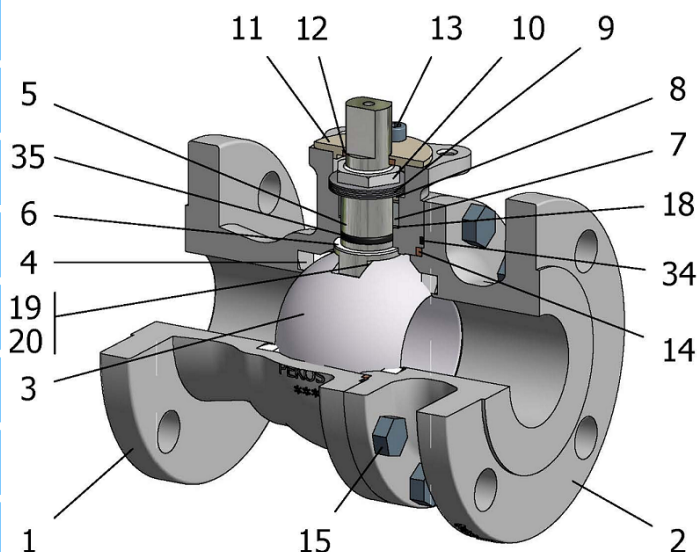

FIG. 14 TGTGV CL150 1/2"-8"



Position	Description	Material
01	Body 1	C.S. A216 WCC
02	Body 2	C.S. A216 WCC
03	Ball	S.S. A351 CF8M
04	Seat	PTFE
05	Stem	S.S. AISI 316
06	Stem seal	PTFE+FG
07	Stem packing 1	Graphite
08	Gland packing	S.S. AISI 316
09	Spring washer	S.S. AISI 301
10	Stem nut	S.S. AISI 303
11	Cover	S.S. A351 CF8M
12	Cover ring	PTFE
13	Cover bolt	A4-70
14	Body seal 1	PTFE
15	Body bolt	A193 B7M
16	Handle	WCB
17	Handle bolt	1.045(8.8)
18	Thrust washer	PTFE+CG
19	Spring	S.S. AISI 316
20	Antistatic ball	S.S. AISI 316
34	Body seal 2	Graphite
35	O ring stem	Viton

General features

- Floating ball.
- Split body.
- Full bore.
- Soft seat.
- Bidirectional.
- TA-LUFT.
- Anti Blow out proof stem.
- Autoadjustable packing.
- Anti static device.
- Self-cavity pressure relief.

Standards

- Top flange ISO 5211
- Flanges ANSI B16.5
- Face to face ANSI B16.10
- Testing API 598, API 6D, BS 6755-1
- Design AP 6D, B16.34
- Materials according to NACE MR0175

Official approvals

- CERTIFICATE FIRE SAFE
- TA-LUFT
- ATEX 94-9EC
- API 6D.
- PED 97/23/CE.
- SIL 3 CAPABLE

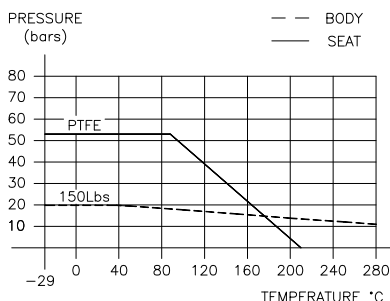

PEKOS GROUP CERTIFICATES:
ISO 9001-2008 / 97-23-CE / API-6D



DIMENSIONS & Technical information

DN	CL	D	L	E	A	B	C	F	H	G	V	X	Y	Z	n x d	ISO 5211	Torque	MAST	Weight
1/2"	150	15	108	89	35	60	11	52	185	103	12	8	13	16	4 x 16	F05	9	43,5	2,5
3/4"	150	20	117	98	43	70	13	54	185	105	12	8	13	16	4 x 16	F05	11	43,5	3,2
1"	150	25	127	108	51	79	14	60	185	111	16	10	19	22	4 x 16	F05	16	80,1	4,2
1 1/2"	150	40	165	127	73	98	18	75	300	129	20	14	22	25	4 x 16	F07	32	80,1	7,4
2"	150	50	178	152	92	121	19	84	300	138	20	14	22	25	4 x 19	F07	48	250,4	10,4
2 1/2"	150	65	190	178	105	140	22	96	300	150	20	14	22	25	4 x 19	F07	62	250,4	17,0
3"	150	80	203	191	127	152	24	114	355	187	25	19	24	27	4 x 19	F10	103	522,5	22,5
4"	150	100	229	229	157	191	24	128	355	201	25	19	24	27	8 x 19	F10	145	522,5	31,6
6"	150	150	394	279	216	241	25	175	680	268	34	26	35	38	8 x 22	F12	400	1073,4	81,1
8"	150	200	457	343	270	298	29	245	750	338	42	32	40	43	8 x 22	F14	720	2544,3	143,0

** Depending on service conditions. * Dimensions are in mm. * Torque & MAST are in Nm * Weight is in Kilograms
* Torque values have been measured ΔP at maximum rating at room temperature