

Bolted bonnet, Outside screw-and-yoke, Rising stem handwheel, Swivel disc.

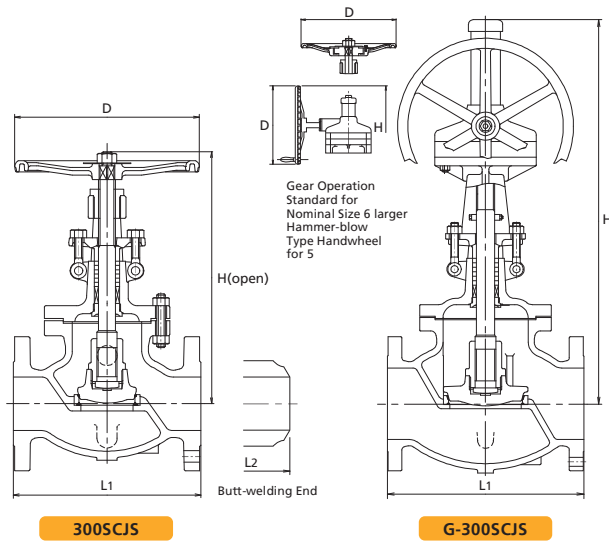

Fig	End Connections
300SCJS	RF-flanged ends.
W300SCJS	Butt-welding ends.

Standard materials of parts

Parts	Materials
Body	ASTM A216 Gr.WCB
Bonnet	ASTM A216 Gr.WCB
Stem	ASTM A276 Tp.403
Disc	13Cr/Carbon Steel+13Cr
Lock nut	ASTM A182 Gr.F6a
Body seat ring	Carbon Steel+HF*
Gland	ASTM A182 Gr.F6a
Gland packing	Flexible Graphite
Gland flange	ASTM A105/A216 Gr. WCB
Handwheel	Ductile iron
Gasket	See Page 6
Bonnet bolt/nut	ASTM A193 Gr.B7/A194 Gr.2H
Gland bolt/nut	ASTM A576 Gr.1045/A194 Gr.2H
Bonnet bushing	ASTM A182 Gr.F6a
Yoke sleeve	ASTM A439 Tp.D2

\*Hard facing with Co-Cr-W Alloy.  
 Note: Refer to Page 5&6 for standard seat material and construction.

Dimensions

Nominal Size		1½	2	2½	3	4	5	6	8	10	12	14	16
		40	50	65	80	100	125	150	200	250	300	350	400
L <sub>1</sub>	in	9.00	10.50	11.50	12.50	14.00	15.75	17.50	22.00	24.50	28.00	33.00	34.00
	mm	229	267	292	318	356	400	444	559	622	711	838	864
L <sub>2</sub>	in	—	10.50	11.50	12.50	14.00	15.75	17.50	22.00	24.50	28.00	33.00	34.00
	mm	—	267	292	318	356	400	444	559	622	711	838	864
H	in	14.3	14.3	17.0	17.2	20.1	24.0	27.0	41.8	45.0	46.8	57.1	55.5
	mm	362	362	433	436	510	610	990	1062	1143	1188	1450	1410
D	in	7.9	7.9	9.8	9.8	13.8	15.7	17.7	19.7	23.6	23.6	23.6	23.6
	mm	200	200	250	250	350	400	500	500	600	600	600	600