

Cast Carbon Steel Check Valve

Bolted cover, Swing type disc.

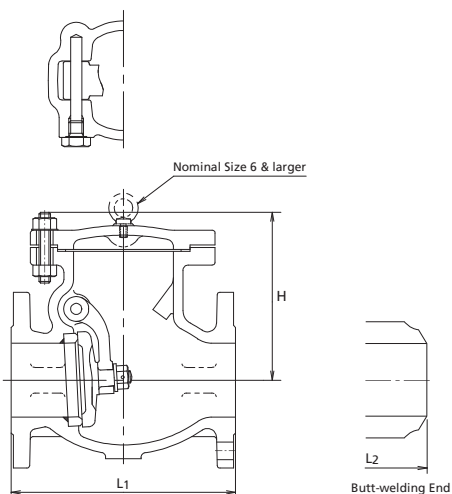

150SCOS

Fig	End Connections
150SCOS	RF-flanged ends.
W150SCOS	Butt-welding ends.

Standard materials of parts

Parts	Materials
Body	ASTM A216 Gr.WCB
Cover	ASTM A105/A216 Gr.WCB
Disc	13Cr/Carbon Steel+13Cr
Disc nut	ASTM A194 Gr.8
Body seat ring	Carbon Steel+HF*
Cover bolt/nut	ASTM A193 Gr.B7/A194 Gr.2H
Arm	ASTM A216 Gr.WCB
Gasket	See Page 6
Plug	ASTM A576 Gr.1045

*Hard facing with Co-Cr-W Alloy.
 Note: Refer to Page 5&6 for standard seat material and construction.

Dimensions

Nominal Size	Nominal Size																		
	1 1/2	2	2 1/2	3	4	5	6	8	10	12	14	16	18	20	24	26	28	30	
	40	50	65	80	100	125	150	200	250	300	350	400	450	500	600	650	700	750	
L ₁	in	6.50	8.00	8.50	9.50	11.50	13.00	14.00	19.50	24.50	27.50	31.00	34.00	38.50	38.50	51.00	51.00	57.00	60.00
	mm	165	203	216	241	292	330	356	495	622	698	787	864	978	978	1295	1295	1448	1524
L ₂	in	—	8.00	8.50	9.50	11.50	13.00	14.00	19.50	24.50	27.50	31.00	34.00	38.50	38.50	51.00	51.00	57.00	60.00
	mm	—	203	216	241	292	330	356	495	622	698	787	864	978	978	1295	1295	1448	1524
H	in	5.3	6.0	6.7	7.1	7.9	9.25	9.8	11.6	13.2	14.5	16.3	18.1	20.1	23.0	24.8	26.8	28.2	29.9
	mm	135	152	170	180	200	235	250	295	334	368	415	460	510	583	630	740	810	871