

# Cast Carbon Steel Gate Valve

Bolted bonnet, Outside screw-and-yoke, Rising stem, Non-rising handwheel, Flexible wedge.

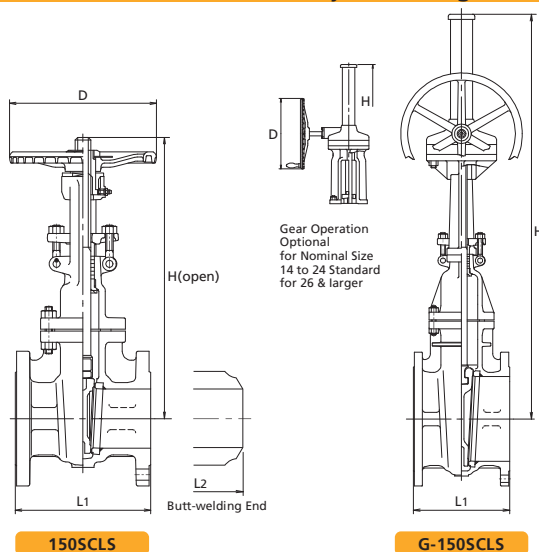

Fig	End Connections
150SCLS	RF-flanged ends.
W150SCLS	Butt-welding ends.

### Standard materials of parts

Parts	Materials
Body	ASTM A216 Gr.WCB
Bonnet	ASTM A216 Gr.WCB
Stem	ASTM A182 Gr.F6a
Disc	13Cr/Carbon Steel+13Cr
Body seat ring	Carbon Steel+HF*
Gland	ASTM A182 Gr.F6a
Gland packing	Flexible Graphite
Gland flange	ASTM A105/A216 Gr. WCB
Handwheel	Ductile iron
Gasket	See Page 6
Bonnet bolt/nut	ASTM A193 Gr.B7/A194 Gr.2H
Gland bolt/nut	ASTM A576 Gr.1045/A194 Gr.2H
Bonnet bushing	ASTM A182 Gr.F6a
Yoke sleeve	ASTM A439 Tp.D2
Grease nipple	Carbon steel

\*Hard facing with Co-Cr-W Alloy.  
 Note: Refer to Page 5&6 for standard seat material and construction.

### Dimensions

Nominal Size	Nominal Size																											
	1 1/2	2	2 1/2	3	4	5	6	8	10	12	14	16	18	20	22	24	26	28	30	32	34	36						
L <sub>1</sub>	in	6.50	7.00	7.50	8.00	9.00	10.00	10.50	11.50	13.00	14.00	15.00	16.00	17.00	18.00	19.00	20.00	22.00	24.00	24.00	26.00	28.00	28.00					
	mm	165	178	190	203	229	254	267	292	330	356	381	406	432	457	483	508	559	610	610	660	711	711					
L <sub>2</sub>	in	—	8.50	9.50	11.14	12.00	15.00	15.86	16.50	18.00	19.76	22.50	24.00	26.00	28.00	30.00	32.00	34.00	36.00	36.00	38.00	40.00	40.00					
	mm	—	216	241	283	305	381	403	419	457	502	572	610	660	711	762	813	864	914	914	965	1016	1016					
H	in	15.2	15.2	17.0	20.1	23.3	25.9	29.9	37.8	45.8	53.6	61.9	66.6	74.3	83.6	91.6	98.1	111.6	118.7	123.4	132.3	141.7	149.0					
	mm	385	385	432	509	592	658	758	958	1162	1362	1572	1692	1888	2123	2326	2497	2835	3015	3135	3360	3600	3785					
D	in	7.9	7.9	7.9	9.8	9.8	11.8	11.8	13.8	15.7	17.7	19.7	23.6	23.6	26.8	26.8	29.9	19.7	23.6	23.6	23.6	23.6	23.6					
	mm	200	200	200	250	250	300	300	350	400	450	600	600	600	680	680	760	500	600	600	600	600	600					