

Cast Carbon Steel Globe Valve

Bolted bonnet, Outside screw-and-yoke, Rising stem handwheel, Swivel disc.

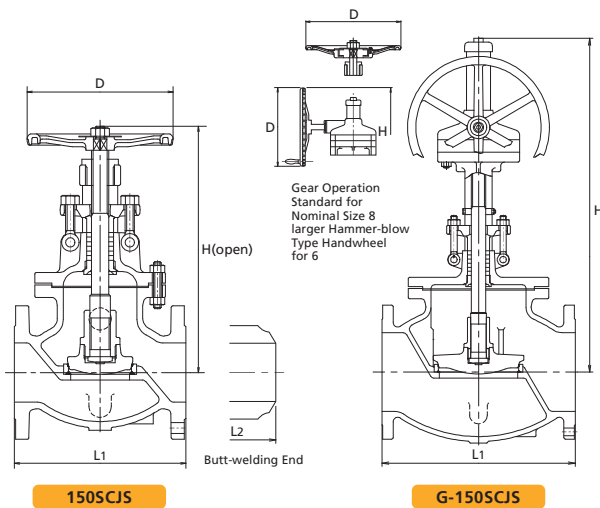

Fig	End Connections
150SCJS	RF-flanged ends.
W150SCJS	Butt-welding ends.

Standard materials of parts

Parts	Materials
Body	ASTM A216 Gr.WCB
Bonnet	ASTM A216 Gr.WCB
Stem	ASTM A276 Tp.403
Disc	13Cr/Carbon Steel+13Cr
Lock nut	ASTM A182 Gr.F6a
Body seat ring	Carbon Steel+HF*
Gland	ASTM A182 Gr.F6a
Gland packing	Flexible Graphite
Gland flange	ASTM A105/A216 Gr. WCB
Handwheel	Ductile iron
Gasket	See Page 6
Bonnet bolt/nut	ASTM A193 Gr.B7/A194 Gr.2H
Gland bolt/nut	ASTM A576 Gr.1045/A194 Gr.2H
Bonnet bushing	ASTM A182 Gr.F6a
Yoke sleeve	ASTM A439 Tp.D2

*Hard facing with Co-Cr-W Alloy.
Note: Refer to Page 5&6 for standard seat material and construction.

Dimensions

Nominal Size	Nominal Size													
	1 1/2	2	2 1/2	3	4	5	6	8	10	12	14	16	18	
L ₁	in	6.50	8.00	8.50	9.50	11.50	14.00	16.00	19.50	24.50	27.50	31.00	36.00	38.50
	mm	165	203	216	241	292	356	406	495	622	698	787	914	978
L ₂	in	—	8.00	8.50	9.50	11.50	14.00	16.00	19.50	24.50	37.50	31.00	36.00	38.50
	mm	—	203	216	241	292	356	406	495	622	698	787	914	978
H	in	13.1	13.1	14.9	15.4	18.1	19.1	20.2	24.8	38.5	41.3	43.5	48.2	49.8
	mm	332	332	379	390	460	484	513	929	979	1049	1106	1224	1275
D	in	7.9	7.9	9.8	9.8	9.8	11.8	13.8	15.7	19.7	19.7	19.7	23.6	23.6
	mm	200	200	250	250	250	300	350	500	500	500	500	600	600